

Everllence

PrimeServ

# Retrofit & upgrade



Products  
services  
portfolio

Four-stroke GenSet  
solutions



# Optimized equipment

Your partners for retrofit solutions



Reliability, enhanced efficiency and compliance with new environmental legislation are just a few of the benefits that our advanced retrofit solutions provide.

## Keeping your equipment consistently up to date

Your existing GenSet engines and control systems might be aging, but that does not mean they cannot continue to deliver value. Our comprehensive, tailored retrofit solutions will keep your assets up-to-date through continuous development and modernization.

The Everllence PrimeServ retrofits and upgrades for Everllence four-stroke GenSet engines will help you improve efficiency, boost reliability and performance, save fuel and lubricating oil, while lowering maintenance costs and enabling a more flexible operation.

These retrofits and upgrades will also help you comply with increasingly stringent environmental regulations and help ensure your operations are on the path to energy transition and decarbonization. And they will benefit your employees by improving crew safety and making the equipment easier to operate.

So, whether you are looking to upgrade your existing GenSet systems for improved reliability, fuel and lubricating oil savings, lower maintenance costs, or equipment upgrades, Everllence PrimeServ offers powerful retrofit solutions for your vessels in service.

**Lube oil optimization****06-07**

Lube oil centrifugal filter

06

**Safety & reliability****08-17**

Multifunction monitoring system

08

Electronic overspeed protection

10

Engine control box replacement

12

Safety system PLC replacement

14

Speed converter replacement

16

**Operational improvement****18-25**

Charge air preheater

18

Fuel system pressure pulsation damper

20

Fuel system upgrade package

22

Mk. 2 upgrade for L16/24 Tier I Mk. 1

24

**Product overview****26-27****Service with passion****28-29****Worldwide service****30-31**

# Lube oil centrifugal filter

Installing the Lube oil centrifugal filter as an in-line filter will remove contaminants and small solid particles from the lubricating oil.

Everllence GenSet engines have brought value to owners of power plants and vessels for many years. GenSet engines built two or more decades ago continue to deliver value today.

However, contaminants in the lubricating oil can in some cases lead to soot formation, which contributes to engine component wear as well as increasing the viscosity of the lubricating oil. An effective filter is key to mitigating this. The Lube oil centrifugal filter has been specifically designed to filter out contaminants and small solid particles as an addition to the standard full-flow (also known as in-line) filter or separator unit.

## Lube Oil Centrifugal Filter as an in-line filter reduces engine wear

The Lube oil centrifugal filter extends the lifetime of the primary lube oil filter and reduces wear on the engine. It also ensures proper performance and a long lifetime of the lube oil. When installed as a secondary filter, it removes high-density particles down to submicron level. Lube oil centrifugal filter is a bypass (also known as in-line) filter. It extracts portion of the lube oil and spins it at up to 8,000 rpm before returning it to the oil sump.

## Easy installation and maintenance

Installation on the engine types L16/24, L21/31, and L27/38 is fast and easy. You will need a tailored solution for the L23/30, L28/32H, and V28/32S type engines – ask your Everllence PrimeServ office.

Taking off the centrifuge bowl is simple, and the exchangeable paper insert facilitates easy periodic cleaning.

Please contact your Everllence PrimeServ office for more details.



## Efficient engine protection with powerful filtration

### Key benefits

- Extends the service life of lube oil and primary filters
- Reduces engine wear
- Reduces engine downtime
- Reduces overhaul costs
- Acts as an indicator of lube oil cleanliness and the efficiency of the primary filter
- Exchangeable paper insert makes filter cleaning easy

### Scope of supply

- Centrifugal filter unit
- Crankcase cover (only if pipes are not installed at the base frame)
- Pipe
- Valve
- Fittings and other installation accessories

### Applicable to

Available for the engine types L16/24, L21/31, L23/30H, L27/38, L28/32H, and V28/32S

# Multifunction monitoring system

The Multifunction Monitoring System provides temperature monitoring to protect against main bearing failure.

Everllence GenSet engines have brought value to owners of power plants and vessels for many years. GenSet engines built two or more decades ago continue to deliver value today. However, changes in the composition of the fuel oil mean that more particles are carried over to the lubricating oil, and catalytic (cat) fines cause abrasive wear on the crankshaft and bearing surfaces.

A built-in oil mist detector shuts down the engine when oil mist appears. This prevents severe crankshaft damage or connecting rod breakage. However, the shutdown may occur too late to prevent the damage caused by the lube oil particles. Therefore, the use of a Multifunction monitoring system is necessary.

## Investment in temperature monitoring to prevent main bearing failure

Our Multifunction monitoring system, featuring a shutdown mechanism, is a vital safety feature safeguarding engines from such issues.

Sensors in the main bearing cap track bearing temperatures, while others inside the crankcase cover monitor splash oil temperatures for each cylinder. A display with color bars visually warns when temperatures near a set level. If critical temperatures are exceeded, the system triggers an engine shutdown. Furthermore, all collected data assists in predictive maintenance procedures.

## Other useful options

The Multifunction monitoring system can include other options, such as pressure monitoring to indicate the condition of cylinder liners and piston rings as well as monitoring to show when it is time to clean the charge air cooler for optimal combustion and fuel economy.

Please contact your Everllence PrimeServ office for more details.



## Protect bearings with data-driven predictive maintenance

### Key benefits

- Reduces the risk of damage due to main bearing failure
- Prevents costly repairs of critical engine parts and engine downtime
- Triggers engine shutdown if temperature levels indicate that engine damage is imminent
- Ensures continuous temperature monitoring of main bearing and splash oil

### Scope of supply

- Cabinet with control box configured with software parameterized according to engine type
- Temperature sensors with mounting kits for engine frame side covers
- Temperature sensor with mounting kits for main bearing
- Junction box type A10
- Cables
- Installation accessories
- Special tools needed for the installation
- Spare part plates
- User manual for the software system (Multifunction monitoring system)

### Applicable to

Available for the engine types L16/24, L21/31, L23/30H, L27/38, L28/32H, and V28/32S

# Electronic overspeed protection

The Electronic Overspeed Protection supplements the mechanical overspeed device to ensure efficient engine speed monitoring and engine shutdown in case of overspeed.

Service Letter SL2020-702 published in 2020 emphasized that the overspeed system must be tested according to classification society rules and the safety precautions in the instruction manual. But from time to time, Everllence PrimeServ still sees engines of the types L23/30H and L/V28/32 at risk of severe damage due to overspeed. These cases are the result of lack of maintenance, testing, and adjustment of the mechanical overspeed device.

Everllence PrimeServ recommends that you install the Electronic Overspeed Protection to prevent the risk of uncontrolled engine overspeed. The Electronic Overspeed Protection reduces the risk of damage to valve gear, pistons, connecting rod and, in the worst case, replacement of frame and crankshaft.

### Operational benefits

The Electronic Overspeed Protection is an additional precaution to provide enhanced reliability of the safety shutdown mechanism, minimizing the

risk of a total breakdown due to overspeed.

The electronic system can replace the existing mechanical overspeed device, or you can keep the existing overspeed device and install the electronic system as an additional and more reliable safety measure.

### Specification

The electrical cabinet is installed either on the engine, outside the charge air space of the engine frame, or externally on a bulkhead or other structure close to the engine.

Cables are routed separately from the control cabinet; one to the sensor and one to the solenoid valve, as these have separate locations on the engine. The control unit is powered by the existing "engine automatic system" (box W75 – see Figure 1).

Please contact your Everllence PrimeServ office for more details.

## Protect GenSet from uncontrolled overspeed

### Key benefits

- Minimizes the risk of breakdown due to overspeed of engine
- Easy to test by simulating overspeed instead of actually overspeeding the engine
- More reliable overspeed protection
- Efficient regardless of lubricant residue or debris around the mechanical trip
- Easy installation with no modification of engine components

### Scope of supply

- Cabinet with control panel, containing a PLC (programmable logic controller)
- Electronic inductive speed pickup sensor
- Pressure switch and needle valve for lube oil pressure
- Pneumatic solenoid valve
- Shuttle valve – for installation in parallel with the mechanical overspeed protection
- Installation accessories

### Applicable to

Available for engine types L23/30H, L28/32H, and V28/32S

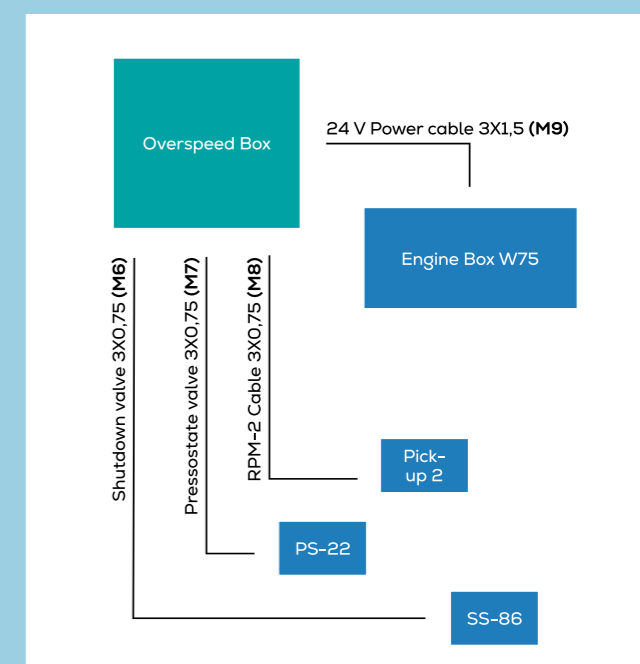

Figure 1: Box W75

# Engine control box replacement

The Engine control box updates the original relay box for the control system due to technological advancements. This leads to higher operational reliability and safer engine operation.

Everllence GenSet engines have brought value to owners of power plants and vessels for many years. GenSet engines built two or more decades ago continue to deliver value today.

As part of the continuous development of our engines and availability of new electronic technology, Everllence PrimeServ has introduced a new control box, which fully replaces the existing relay box and includes multiple updated features. Further details are available in service letter SL05-458/JXN.

**Proactive replacement lowers risk of downtime**  
Replacing a relay box with a new PLC-based control box can be time-consuming when it hasn't been planned in advance. A relay failure may therefore lead to prolonged downtime. By proactively replacing this control system component proactively with the Engine control box replacement, you can avoid this risk.

## More than a control box

The new control system consists of a PLC (programmable logic controller) and a built-in touchscreen display with more settings to interact with, as well as more alarms that can trigger intervention in the engine operation whenever necessary.

The display on the cabinet includes an option to switch between local control from the engine room and remote control from the control room. The system includes our Engine control box replacement retrofit, which improves the engine safety as it reacts faster than the mechanical overspeed protection. In addition, a new tachometer display will be installed on the engine.

Please contact your Everllence PrimeServ office for more details.

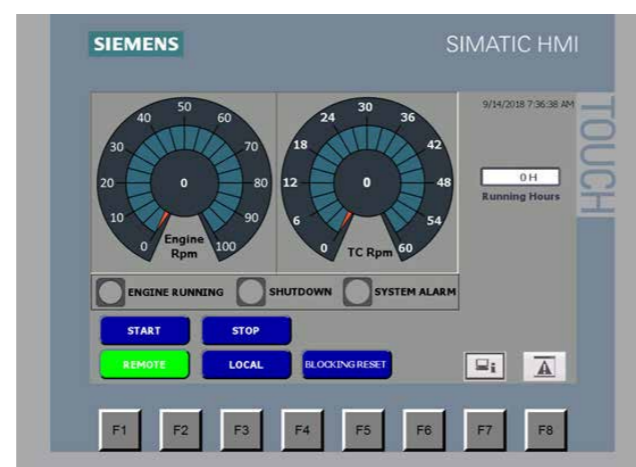

## Update obsolete systems

### Key benefits

- Updated control box system, improving the component's lifetime, functionalities, and operational uptime
- Prevention of unplanned GenSet downtime due to control system failure
- High operational reliability
- Easy access to main functions via touchscreen
- Added functionality and connectivity to the engine control room

### Scope of supply

- Cabinet with touchscreen display, containing PLC modules
- Electronic inductive speed pickup sensor for electronic overspeed protection
- Separate tachometer display for installation on the engine
- Installation accessories
- New electrical drawings
- New set of spare part platess

### Applicable to

Available for the engine types L23/30H, L28/32H, and V28/32S

# Safety system PLC replacement

With a Safety system PLC replacement, Everllence PrimeServ fully updates the original system PLCs with Siemens S7 PLCs.

Everllence GenSet engines have brought value to owners and operators for many years. GenSet engines built two or more decades ago continue to deliver value today. However, some safety system PLCs (programmable logic controllers) are not produced anymore, and spare parts are either unavailable or can be hard to find. If the safety system fails, the vessel crew or power plant staff must take the GenSet out of operation.

## Proactive replacement lowers the risk of downtime

Replacing a PLC with a different model it can be time-consuming if not planned in advance. A PLC failure may therefore lead to prolonged downtime. By proactively replacing the PLCs proactively with PLCs from the Siemens S7 series, you can avoid this risk.

The Safety system PLC replacement installation requires specific knowledge about Everllence GenSet engines. Therefore, a Everllence PrimeServ service engineer will take care of the installation.

Implementing this PLC system of all Everllence GenSet safety systems on your vessel or power plant will reduce total costs.

## Replace now and improve reliability immediately

The PLCs listed below, including the ABB CS31, ABB AC1131, Allen Bradley Micrologix 1500, and ABB EcoFlex 500, have ceased production.

This is why it is recommended to replace all the listed PLCs with the Safety system PLC replacement at your earliest convenience. For this, an upgrade service package that includes all necessary hardware and software is available. Further details are available in the service letter SL2020-700/MNS.

Please contact your Everllence PrimeServ office for more details.



## Strengthen operational reliability

### Key benefits

- Updated PLC replacement system, improving the component's lifetime, functionalities, and operational uptime
- Prevents prolonged GenSet downtime due to a defective PLC
- Prevents lack of power at a critical time
- Increases the general reliability of the GenSets
- Improves the repair options and lowers future safety system repair costs

### Scope of supply

- Siemens S7 PLC module – one for each engine
- For the engine types L16/21, L21/31 and L27/38, control software for the retrofit "Charge Air Preheater" is included as standard in the new PLC
- One spare control system base module for replacement if needed
- Installation accessories
- New electrical drawing
- New set of spare part plates

### Applicable to

Available for the engine types L16/24, L21/31, L23/30H, L27/38, L28/32H, and V28/32S

# Speed converter replacement

The Speed converter replacement takes over the original Deuta werke tacho converter for monitoring speed through a sensor and displaying it on the tachometers.

Everllence GenSet engines have brought value to owners of power plants and vessels for many years. GenSet engines built two or more decades ago continue to deliver value today. However, some electronic equipment is no longer produced, and spare parts are not available. One example is the Deuta werke tacho converter. If it fails, the vessel crew or power plant staff must take the GenSet out of operation.

## Proactive replacement lowers the risk of downtime

Replacing a Deuta werke tacho converter with a new model takes time when it has not been planned in advance. A tacho converter failure may therefore lead to prolonged downtime. By proactively replacing it, you can avoid this risk.

## Speed converter replacement developed for Everllence GenSet engines

Everllence PrimeServ has developed the Speed converter replacement specifically to replace the Deuta werke tacho converter.

The Speed converter replacement contains a so-called MAS module, which is a PLC with preconfigured software. The design includes a pulse-type pickup sensor mounted at the engine gearwheel.

The sensor pulses are converted to 4-20 mA signals, which are transmitted to the tachometers. It can also be used to shut down the engine at overspeed, display tacho failures, and start the engine in safe mode, depending on the requirements.

As the replacement work requires specific product knowledge, a Everllence PrimeServ service engineer will take care of the installation.

Please contact your Everllence PrimeServ office for more details.

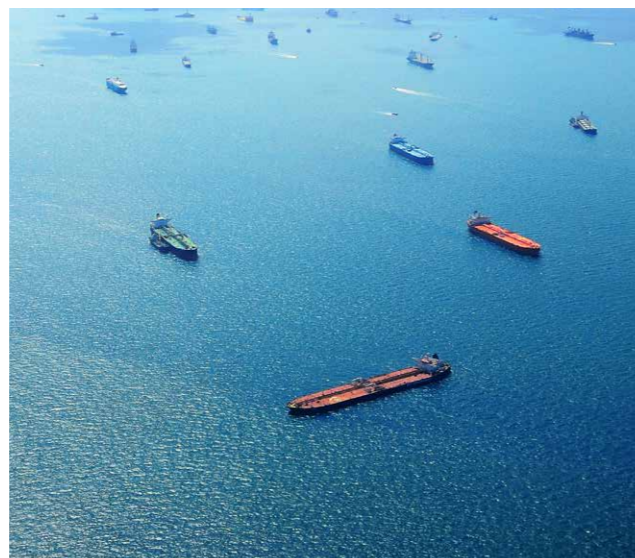

## Enhance engine safety with advanced speed monitoring

### Key benefits

- Updated speed converter system, improving the component's lifetime, functionalities, and operational uptime
- Updates the speed converter to a software-based platform
- Increases engine reliability
- Easy electrical installation, requires very few modifications on the engine

### Scope of supply

- MAS module
- Start box with overspeed lamp (for installation inside the cabinet)
- Relays (for installation inside the cabinet)
- Cabinet and rubber dampers (only if the existing cabinet cannot be used)
- Cable and electrical wires
- Installation accessories
- New electrical drawing

### Applicable to

Available for the engine types L23/30H and L28/32H

# Charge air preheater

The Charge air preheater lowers the charge air cooling to reduce soot accumulation during low-load operation.

Everllence GenSet engines have brought value to owners of power plants and vessels for many years. GenSet engines built two or more decades ago continue to deliver value today.

However, to comply with emission limits and to save fuel, it has become necessary to run the GenSet engines at low load more often, even though the changed usage pattern causes poor combustion, leading to internal soot accumulation and increased contamination of the lube oil.

## Reduced operating and maintenance costs

Increasing the charge air temperature improves the fuel ignition. This leads to better combustion, resulting in fewer deposits, especially in the combustion chamber and at the exhaust valves. Consequently, the Charge air preheater reduces the operating and maintenance costs of GenSets running on heavy fuel oil.

The Charge air preheater works by means of a charge air cooler (CAC) bypass valve. When the GenSet engine is running below 40% of its maximum load, the engine control system, or a separate control system, activates the CAC bypass valve.

The Charge air preheater installation involves a simple pipe modification and installation of the CAC bypass valve. On the engine types L16/24, L21/31 and L27/38, the Charge air preheater is installed in the front-end box.

Please contact your Everllence PrimeServ office for more details.



## Improve performance during low-load operation

### Key benefits

- Enhances performance during periods of low-load running
- Reduces deposits in the combustion chamber and at the exhaust valves
- Less contamination of the lubricating oil
- Prevents excessive wear on engine components
- Leads to longer maintenance intervals
- Installation is simple – does not require major changes to engine parts

### Scope of supply

- Charge air cooler (CAC) bypass valve (3-way valve with actuator)
- For L23/30H and L28/32H: control panel (with PID controllers for temperature adjustment)
- Temperature sensor
- Pressure switch
- Installation accessories

### Applicable to

Available for the engine types L16/24, L21/31, L23/30H, L27/38, and L28/32H

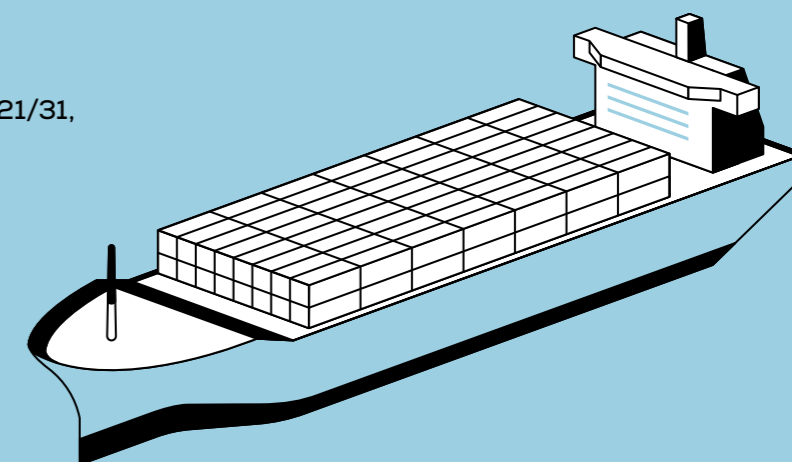

# Fuel system pressure pulsation damper

The Fuel system pressure pulsation damper relieves pulsation vibrations in the fuel system to increase the lifetime of pressure sensors and manometers and prevent pipe leakages.

Everllence GenSet engines have brought value to owners of power plants and vessels for many years. GenSet engines built two or more decades ago continue to deliver value today. However, for some of the L21/31 and L27/38 engines, the fuel is delivered through relatively small external fuel supply systems. Small pipe dimensions cause pump pulsations that spread throughout the piping system as vibrations.

Fuel pulsations can cause cavitation, which over time may lead to pipe damage, leakage, and shorter time between overhaul (TBO).

#### Extends the lifetime of equipment

The Fuel system pressure pulsation Damper limits the pulsation in the fuel system for four-stroke engines. When installed, it helps prevent cavitation and pipe leakages, ensuring a longer lifetime of pressure sensors and manometers. All of these, contribute to a longer TBO. The pulsation damper is installed in the low-

pressure fuel supply system, upstream of the first fuel pump on the engine. It reduces the pressure on both the inlet and the outlet signals. A small spring-loaded piston in the Pulsation Damper evens out the fuel pulsation, leading to reduced vibration.

Please contact your Everllence PrimeServ office for more details.

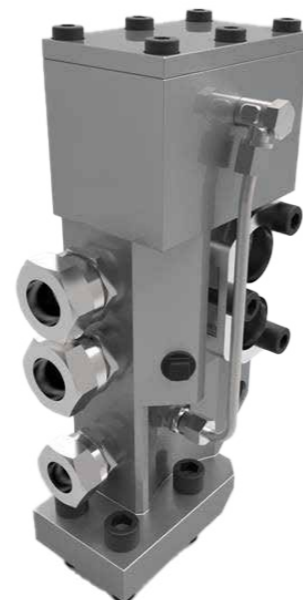

## Prolong TBOs and engine components lifetime

#### Key benefits

- Minimizes pipe vibrations from small fuel supply systems
- Prevents pipe leakages and cavitation
- Increases the lifetime of pressure sensors and manometers
- Easy "plug-and-play" installation on the engines

#### Scope of supply

- Complete pulsation damper
- Leak oil pipes
- Adjustable elbow coupling
- Banjo coupling
- Other installation accessories

#### Applicable to

Available for the engine types L21/31 and L27/38

# Fuel system upgrade package

The Fuel system upgrade package enhances the fuel treatment to help eliminate consequences of changed usage patterns and increased concentration of particles in the fuel oil.

The Everllence GenSet engines have brought value to owners of power plants and vessels for many years. GenSet engines built two or more decades ago continue to deliver value today. However, catalytic (cat) fines from low-sulfur fuel oil can cause abrasive wear on the engine components. To reduce emissions and save fuel, GenSet engines now run on low load for long periods of time.

Cat fines in the fuel oil and the changed usage patterns affect the fuel nozzles, so they need to be replaced frequently, even after only 400 running hours. Poor performance of fuel nozzles leads to issues with valves, nozzle rings, turbocharger performance, cylinder units, and the lubricating oil. This leads to higher maintenance costs and increased risk of GenSet engine failure.

## Improved fuel cleaning lowers the maintenance costs

The two fuel oil filter units in the Fuel system upgrade package will significantly improve fuel cleaning, protecting essential engine parts against wear and carbon soot deposits. Small turbochargers are more sensitive to fouling than large ones. To facilitate turbocharger cleaning, the package includes two cleaning devices.

Installing the 10 µm backflush filter from the Fuel system upgrade package has extended the service hours of the fuel injection nozzles to up to 8000 hours. As an alternative to the complete package, you have the option to purchase just a part of it.

Please contact your Everllence PrimeServ office for more details.

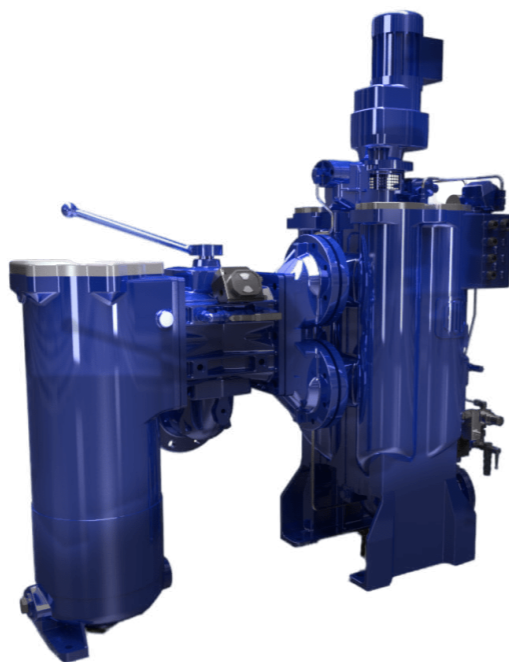

## Improve GenSets' service life

### Key benefits

- Minimizes unplanned maintenance and off-hire time
- Longer lifetime of fuel nozzles
- Improved combustion throughout the lifetime of the fuel injection nozzles
- Prevents valves from sticking
- Longer cleaning intervals at the turbocharger turbine side
- Less lubricating oil contamination from cat fines
- Better turbocharger performance
- Less fouling of turbocharger
- Less wear on the turbocharger nozzle ring
- Less wear on piston scraper rings and cylinder liner
- Improved protection of bearings because the lubricating oil contains fewer abrasive particles

### Scope of supply

- New fuel injection nozzles – same standard as for new engines
- Duplex fuel-oil filter – safety filter, in case of fuel separation system failure
- Turbocharger water-flushing device to improve turbocharger performance through cleaning
- Turbocharger dry-cleaning device to improve turbocharger performance through cleaning
- One 25-kg bag of nutshell granulate for turbocharger dry-cleaning. Corresponds to roughly 2–3 months consumption

### Applicable to

Available for the engine types L16/24 Mk. 2 (for L16/24 Mk. 1 together with the Mk. 2 Upgrade), L21/31, L23/30H, L27/38, L28/32H, and V28/32S



# Mk. 2 upgrade for L16/24 Tier I Mk. 1

In 2008, Everllence PrimeServ developed an operational improvement package, Mk. 2 Upgrade for L16/24 Tier I Mk. 1, to eliminate major damage caused by collision between valves and piston crown, and to increase the operational stability of the engine.

Some operators have previously experienced issues with sticking valves as a result of low-load operation or inadequate treatment/quality of heavy fuel oil. Sticking valves can result in damage to valve spindles, piston crowns, rocker arms, and the turbocharger.

Everllence PrimeServ strongly recommends complying with the below service letters, as well as staying up-to-date with past and future service letters about L16/24. Moreover, Everllence PrimeServ strongly recommends installing the necessary retrofit products and adhering to the current operation procedures and maintenance routines in accordance with the following service letters:

- SL2016-615/JFH Automatic backflush filter 10/6 µm
- SL2013-577/KEL Fuel oil safety filter duplex 25/10 µm
- SL2015-597/HCL Water washing/dry cleaning devices for TC

To save costs, we recommend upgrading the L16/24 Tier I Mk. 1 during a major overhaul. The upgrade includes new complete cylinder units, as described in the to-whom-it-may-concern letter – Mk. 2 Update, dated 28 April 2023. With the upgrade kit, Everllence PrimeServ will supply the necessary amendment to the engine Technical File stating compliance with the new IMO-marked components.

The Mk. 2 upgrade improves the combustion and valve motion, extends the service life of essential components and, thereby, increases the time between overhauls (TBO) from 12,000 hours to 16,000 hours.

The Mk. 2 upgrade can include inspection of and, if needed, overhaul of the fuel system, turbocharger, charge air cooler, thermostatic valves (water), engine room ventilation and pressure, and conical elements.

Please contact your Everllence PrimeServ office for more details.



## Improve TBOs with the Mk. 2 upgrade

### Key benefits

- Improved fuel savings
- Extends the TBO from 12,000 to 16,000 hours
- Increased engine operation stability
- Low-profile camshaft sections with lower lift
- Machined piston crowns eliminating piston-to-valve contact
- New stronger valve springs
- New type of valve guide
- Improved valve rotors
- Anti-turning device for valve bridge

### Scope of supply

- New complete cylinder unit with valves, valve guides, rotocaps, spring housings, and connecting rod bearings
- Low-lift camshaft sections (valves)
- Gasket set for complete cylinder unit exchange
- Fuel nozzles (Woodward or L'Orange)
- Tool for adjustment of roller guide bracket
- Tool for easy/safe adjustment of valve clearance
- New pages for the instruction manual
- All NOx Technical File amendments

### Applicable to

Available for the engine type L16/24 Tier I Mk. 1

# Product overview

## Retrofit & upgrade

Benefits	Lube oil centrifugal filter	Multifunction monitoring system	Electronic overspeed protection	Engine control box replacement	Safety system PLC replacement	Speed converter replacement	Charge air preheater	Fuel system pressure pulsation damper	Fuel system upgrade package	MK.2 upgrade
Save fuel oil	✓						✓		✓	
Save lubricating oil									✓	
Flexible operation		✓	✓					✓	✓	
Reduce emissions									✓	
Reduce maintenance	✓		✓	✓	✓	✓	✓	✓	✓	
Improve TBO	✓						✓			✓
Improve performance	✓	✓	✓	✓		✓			✓	✓
Improve safety		✓	✓	✓						
Reduce downtime	✓	✓		✓					✓	
Applicable for										
L16/24	✓	✓			✓		✓		✓	✓
L23/30	✓	✓	✓	✓	✓	✓	✓		✓	
L21/31	✓	✓			✓		✓		✓	
L27/38	✓	✓			✓		✓	✓	✓	
L28/32	✓	✓	✓	✓	✓	✓	✓	✓	✓	
V28/32	✓		✓	✓	✓			✓	✓	

### Lube oil optimization

Optimize lube oil consumption while enabling flexible operation, increasing the time between overhauls, and reducing maintenance.

### Safety & reliability

Safeguards engine, equipment and personnel, while improving the overall reliability of engine equipment.

### Operational improvement

Prolong time between overhauls, reduce operational costs, and extend the lifetime of the engine equipment.

# PrimeServ Service with passion

Everllence PrimeServ is the dedicated Everllence service brand. Via a network of over 100 service centers worldwide, Everllence PrimeServ provides 24/7 service across the globe. Our range of services includes technical support, consulting and OEM spares, as well as maintenance, repair and comprehensive individualized service plans.

# 24

hours a day

# 365

days a year



# Everllence



### Everllence and legacy brands

Everllence PrimeServ is our brand name for high-quality aftersales support for the entire Everllence product portfolio. Through refinements to our products and repair techniques, we ensure and enhance our technological leadership and technical expertise as an original equipment manufacturer (OEM) for the brands united under Everllence.

### Everllence PrimeServ's aim is to provide

- Prompt delivery of high-demand OEM spare parts within 24 hours
- Fast, reliable and competent customer support
- Individually tailored O&M contracts
- Ongoing training and qualification of operators and maintenance staff
- Global service, 24 hours a day, 365 days a year
- Diagnosis and troubleshooting with our high-performance online service

# Worldwide service

We offer retrofitting and upgrade services to bring engines and turbochargers already in service up to the very latest standards of performance and efficiency.



# 100

Services centers worldwide

Represented in all key markets and major ports, with a network of more than 100 service centers, and with skilled field service managers at the ready to provide first-class technical support, Everllence PrimeServ is fully primed to provide 24/7 service, wherever you are. In power plants, marine engines & systems and turbomachinery, offering reliable technical support when you need it most, our service solutions include OEM spare parts, engine and machinery maintenance and repairs, customized service agreements, and individual consulting.

For existing equipment, our holistic retrofit and modernization solutions keep your engines or

turbochargers up-to-date and at optimal levels of reliability, availability, and economic efficiency. Through cutting-edge digital technology we are able to enhance performance and minimize downtimes, while our remote connections enable live data analysis, ensuring quick, and effective solutions. Everllence PrimeServ Academies provide expert training courses around the world, developing the operational and maintenance skills required.

For more information please visit [www.everllence.com/primeserv](http://www.everllence.com/primeserv)

# Everllence

## **Everllence PrimeServ**

H. Christoffersensvej 6  
4960 Holeby, Denmark  
RetrofitDK@everllence.com  
[www.everllence.com/primeserv](http://www.everllence.com/primeserv)

MAN Energy Solutions SE has been renamed to Everllence SE and its products are being rebranded from "MAN" and/or "MAN Energy Solutions" to "Everllence". As this is an ongoing process, any reference to "MAN" and/or "MAN Energy Solutions" is actually a reference to "Everllence". All data provided in this document is non-binding. This data serves informational purposes only and is not guaranteed in any way. Depending on the subsequent specific individual projects, the relevant data may be subject to changes and will be assessed and determined individually for each project. This will depend on the particular characteristics of each individual project, especially specific site and operational conditions.

Copyright © Everllence. EVR 000231EN-250600, GKM CPH