

**Everllence**

Four-  
stroke  
marine  
systems

# Naval defense



**Reliable high-power  
marine solutions**



# Moving big things to **zer**





Everlence is the world's leading provider of large-bore engines, turbomachinery, and integrated power systems. 250 years of experience in advanced engineering has prepared us well for our biggest challenge yet: to provide the technical solutions that will drive the global economy into a new carbon-neutral era.

The industries we serve are crucial for the world economy. Most of them are also hard to decarbonize. By providing sustainable solutions for marine transport, power generation, and industrial engineering we boost business and help to bring the world to net zero.

We are the only manufacturer that caters to the whole spectrum of maritime defense applications: from fast patrol boats to large auxiliary ships, from offshore patrol vessels to naval combatants. More than 60 navies rely on our engines to keep their vessels moving.



# Expertise for special situations





### **Security in changing times**

The naval defense segment is growing in the face of national security concerns. With their broad range of tasks, naval vessels are more than ever in the front line, securing national interest and security, and supporting allies.

As long-term partners of the defense market, we are aware of the requirements and constraints of each application and can design a precisely tailored solution, balancing reliability, sustainability, and technological independence.

With our engineering background, broad portfolio of products and strategic control of technologies and production capabilities, we can provide you with reliable and fully integrated naval solutions.

# Four-stroke engines for naval defense

## Offshore patrol vessels

175D GenSet	■	1,440 – 3,800 kW
175D	■	1,740 – 4,400 kW
V28/33D STC	■	5,460 – 10,000 kW

## 08 – 11

## Naval combatants

175D GenSet	■	1,440 – 3,800 kW
L32/44CR	■	3,600 – 6,000 kW
V28/33D STC	■	5,460 – 10,000 kW

## 12 – 15

## Logistics and supply ships

175D GenSet	■	1,440 – 3,800 kW
175D	■	1,740 – 4,400 kW
L32/44CR GenSet	■	3,600 – 6,000 kW
L32/44CR	■	3,600 – 6,000 kW
L48/60CR	■	7,200 – 10,800 kW
V32/44CR GenSet	■	7,200 – 12,000 kW
V32/44CR	■	7,200 – 12,000 kW
V48/60CR	■	14,400 – 19,200 kW

## 16 – 19

## Inshore and fast patrol craft

175D	■	1,740 – 4,400 kW
------	---	------------------

## 20 – 23



**175D**  
GenSet

1,440 – 3,800 kW

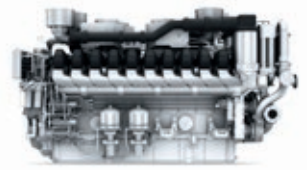

**175D**  
Propulsion

1,740 – 4,400 kW

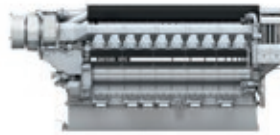

**28/33D STC**  
Propulsion

5,460 – 10,000 kW

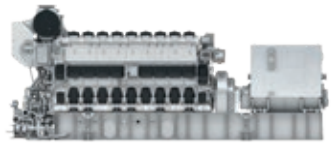

**32/44CR**  
GenSet

3,600 – 6,000 kW  
7,200 – 12,000 kW

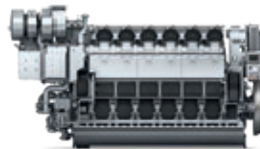

**32/44CR**  
Propulsion

3,600 – 6,000 kW  
7,200 – 12,000 kW

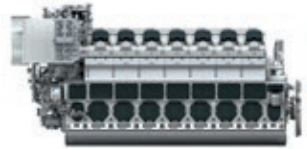

**48/60CR**  
Propulsion

7,200 – 10,800 kW  
14,400 – 19,200 kW



## Offshore patrol vessels

Small and compact, but operating on the open sea, offshore patrol vessels take on a very broad range of missions that include search and rescue, maritime surveillance, environmental monitoring, and fishery protection.

# For a powerful response



© Courtesy of BAE Systems Naval Ships

## Versatile performance

While the engine load profile for a patrol boat has to be very flexible, it almost always has to deliver a quick, high-power response, endurance, and faultless operation during any mission. Easy operation and maintainability are a must.

Our engine options also offer you freedom and flexibility of design, with solutions for both mechanical and hybrid electric propulsion.

28/33D STC

# Fast and dependable

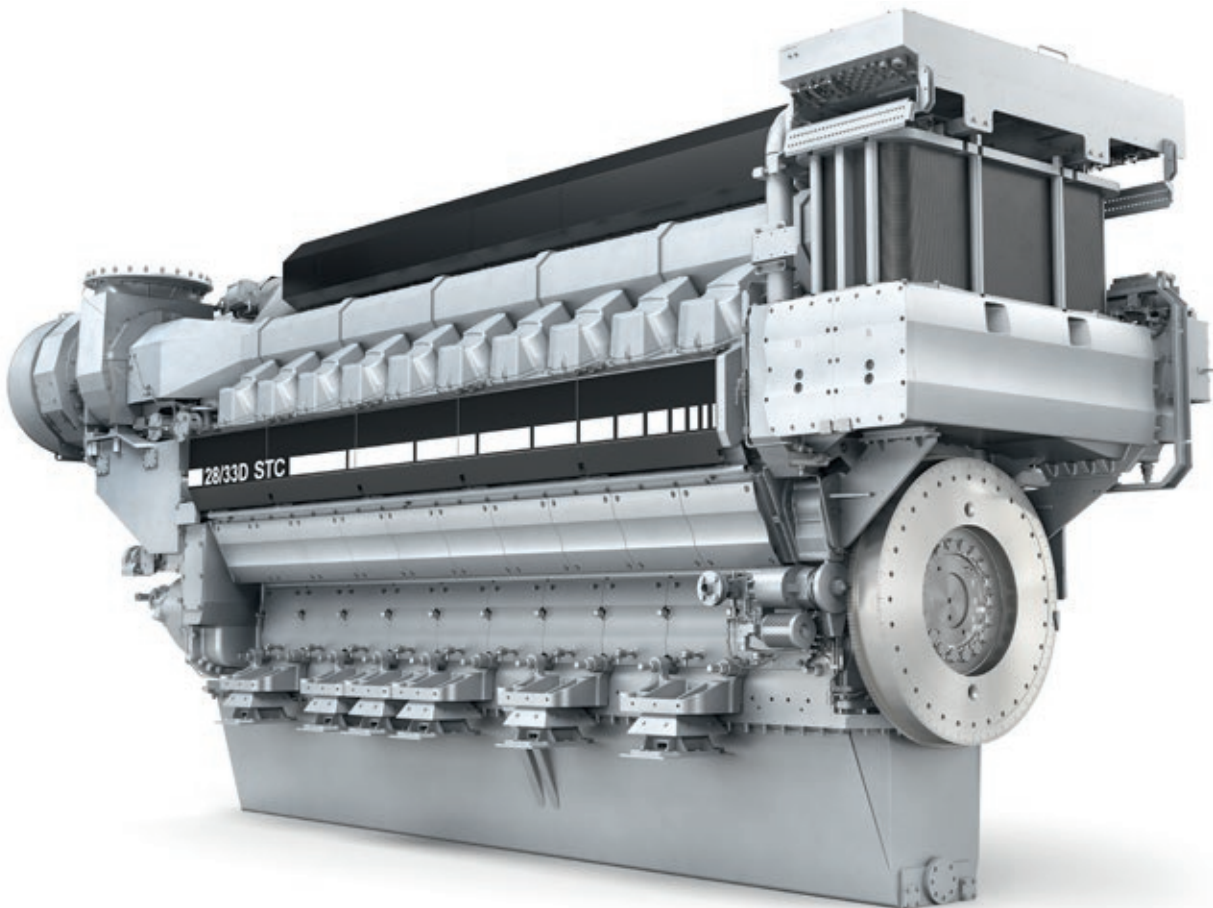

The 28/33D STC features very favorable ratios of power-to-weight and power-to-installation space. Continuous low-load operation capability and high torque for fast acceleration make the 28/33D STC perfect ideal for offshore action. Low fuel consumption, low emissions and reduced life cycle costs make this engine ideal for propulsion in naval and off-shore patrol vessels.

Robust and dependable, not only does the 28/33D STC offer strength and stealth for any mission, but it also keeps downtime low for high availability. In mechanical propulsion systems, it gives you torque that is easy to control and an optimal acceleration response.

### **Benefits**

#### **Economic operation**

One of the lowest total cost of ownership (TCO) on the market

#### **Low maintenance costs**

Due to long time between overhaul (TBO) intervals and onboard maintenance

#### **Best power-to-weight ratio in its class**

5.2 kg/kW, unequaled by any other medium-speed engine

#### **175D GenSet: the perfect combination**

With its continuous, reliable performance and state-of-the-art technology, the 175D GenSet allows you to focus entirely on your mission. Your crew don't have to learn to use different systems: the interface, maintenance procedures, and documentation are aligned and consistent.

#### **Sequential turbocharging (STC)**

Two identical yet independent turbochargers provide high torque at low rpm. Fuel injection quantity, rate, and timing are electronically controlled for perfect acceleration control.

#### **Low acoustic and thermal signature**

Ideal for naval applications. It is capable of extended operation at low loads with high efficiency and minimal heat dissipation.

#### **Further power solutions**

175D GenSet

# Always ready for action

## Naval combatants

Corvettes, frigates, and destroyers depend on high-power, efficient engines that won't let their crews down or risk the success of their missions – whether on far-from-home deployments or fast escort operations.



© Courtesy of BAE Systems Naval Ships

## Silent and swift

Naval combatant applications usually require high speed for fast escort operations, without having to compromise on acoustic, thermal, and visual signatures. They also have to withstand shocks or even be chemical, biological, radiological, and nuclear capable (CBRN).

Our powerful and compact engines deliver this level of performance while ensuring maximum availability and outstanding specific fuel oil consumption (SFOC). Best-in-class life-cycle costs are supported by our worldwide logistics service.

32/44CR

# Robust and flexible

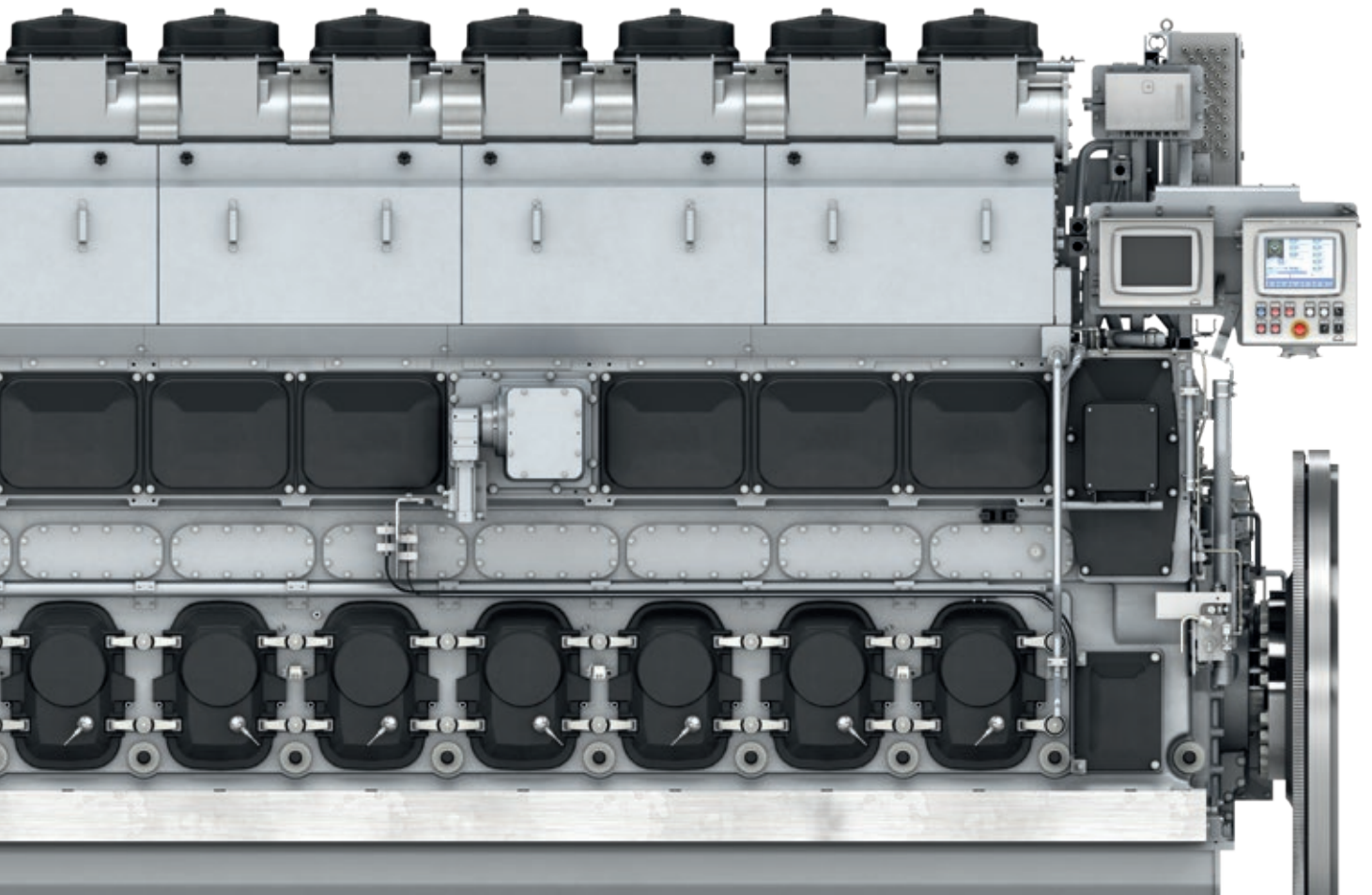

During its development, the 32/44CR has benefited from many years of experience of industrialized diesel engine architecture. It has proven itself in merchant navy applications and can provide a solid reference list. Its high reliability ensures a long TBO.

### **Benefits**

#### **Highly efficient common rail technology**

Best-in-class SFOC

#### **Low operating costs**

Higher efficiency and improved maintainability

#### **Low exhaust emissions**

Complies with IMO Tier II and IMO Tier III (with optional Everllence SCR)

#### **Propulsion and auxiliary power in one**

The 32/44CR is designed as a multi-purpose drive. It can be used for mechanical or diesel-electric propulsion or for diesel-electric power generation. Using it as a marine main engine and auxiliary engine brings huge advantages in terms of operation and support.

#### **Common rail injection**

Allows flexible setting of injection timing, duration, and pressure. This flexibility allows the fuel consumption and emissions to be optimized based on its operating profile.

#### **High efficiency turbocharger**

The use of Everllence turbochargers equipped with the latest high-efficiency compressor wheels can alleviate the NO<sub>x</sub>-SFOC trade-off. The higher pressure ratio increases the efficiency of the engine and therefore compensates for the increase in SFOC normally associated with lower NO<sub>x</sub> emissions.

#### **Further power solutions**

175D GenSet

28/33D STC



## Logistics and supply ships

Naval logistics and supply ships transport munitions, food, fuel, and people over long distances. Non-military deployment can be just as challenging. In disaster relief operations, the ships can act as hospitals, crisis management units, communications centers, or helicopter platforms.

# Backbone of the fleet



## Power for your base at sea

Great demands are made of logistics and supply ships, including a long operational life. World-wide logistic support missions can be long in range and duration. The engines must offer maximum shock resistance, silent operation, and low visual or infrared signatures. The large and complex propulsion systems have to deliver a

high number of running hours and are expected to last for a very long time.

Offering reliable, high power operation with low fuel consumption, our engines pass the test in terms of dependability and economy. What's more, our systems include powerful gensets for integrated electric and hybrid systems.

48/60CR

# Mission reliability

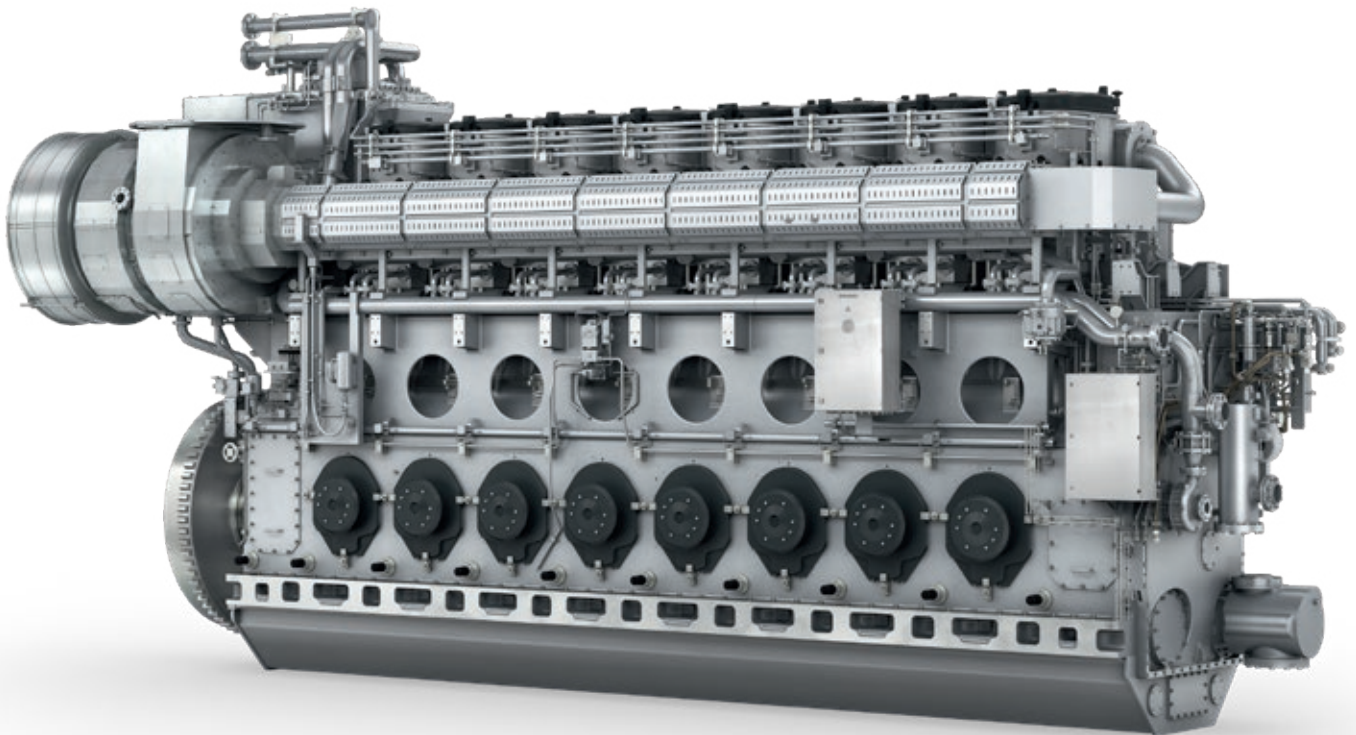

The 48/60CR combines high power output with low fuel consumption. It delivers top performance, operational flexibility and ultimate reliability. Different types of resilient mountings ensure low structure-borne noise.

### **Benefits**

#### **Fuel savings**

Thanks to common rail technology and our innovative Everllence ECOMAP optional feature

#### **Low maintenance costs**

Maintenance-friendly design with long service intervals

#### **High dependability and availability**

Due to the well-established, robust design

#### **Turbocharging system**

The Everllence TCA series exhaust turbocharging system ensures a high compression ratio resulting in high engine efficiency for the 48/60CR. The turbocharging system also facilitates Miller valve timing to reduce pumping losses at low load.

#### **Common rail safety concept**

All high pressure pipes are screened or have a double-wall design. Flow-limiting valves at each cylinder prevent uncontrolled injection. Redundant high pressure pumps and sensors safeguard the operating ability. In single-engine plants, the electronic control units also feature built-in redundancy.

#### **Everllence SaCoSone engine management system**

Ease of operation, outstanding reliability, and fast commissioning are the key features of the Everllence SaCoSone. The system is highly standardized and its modules can be replaced quickly.

#### **Further power solutions**

175D GenSet  
175D  
32/44CR GenSet  
32/44CR

# Quick response



## **Inshore and fast patrol craft**

Inshore and fast patrol craft cover a multitude of coastguard duties, including search and rescue, fire-fighting, environmental surveillance, border control, customs, and police duties. In a military context, they can be deployed as littoral combat crafts, protecting infrastructure or in special operations.



### **Ease of use**

Because they are deployed in coastal waters, engines for inshore patrol craft usually have very high emission compliance standards (IMO Tier III). In terms of performance, an extremely fast response is a must in the majority of cases.

The typically small crews on these boats have their own specialized duties, such as rescue, inspection, and combat. That means that simple engine operation and maintenance is essential.

175D

# High speed, compact size

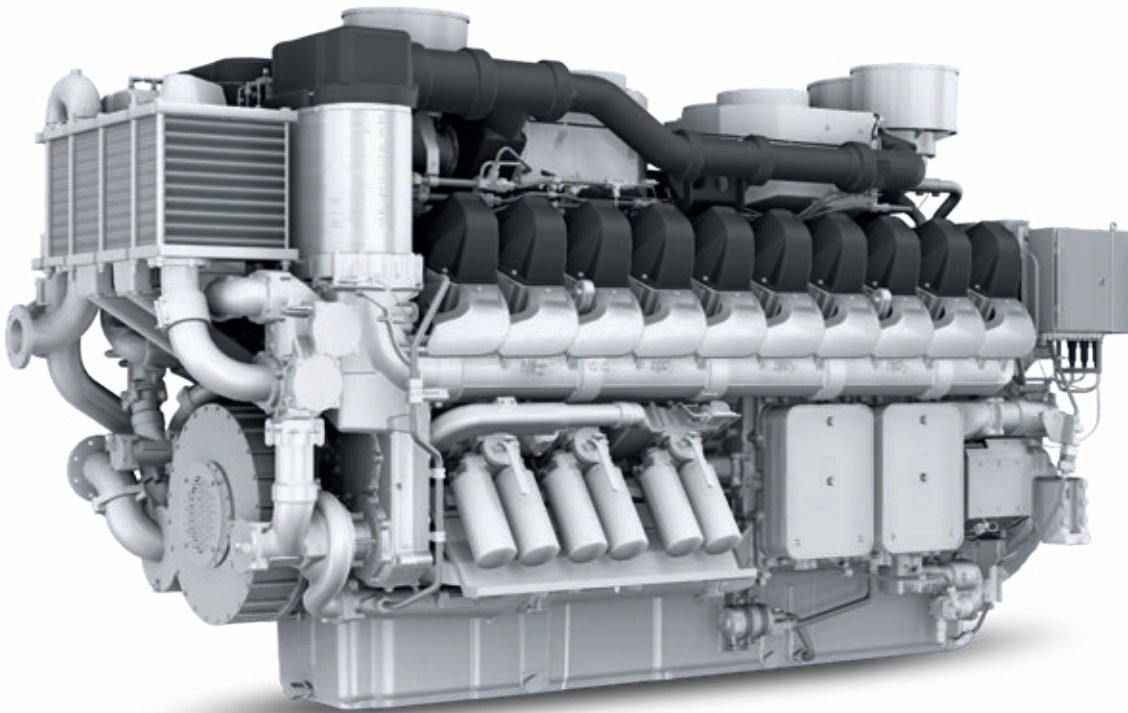

Powerful and compact, the 175D makes sure you are ideally prepared for all types of naval operations. Whether you are patrolling in low-load mode or cruising at full power, the easy handling and high availability of the 175D allows you to focus entirely on your mission.

Packing the latest technology into a minimum volume, this high-speed engine is characterized by its clear-cut design: Easy to commission, easy to operate, and easy to service. Its modular design allows it to meet all the challenges of many different applications.

### Benefits

#### Advanced, powerful, and robust

Peak performance and proven reliability based on cutting-edge technology and successful four-stroke engine tradition

#### Market-leading TBO

Time between major overhaul of up to 30,000 operating hours, whereby the engine is designed such that major overhauls can be carried out in situ

#### Endurance

Market-leading low SFOC allows a longer mission range and the highest combat flexibility

#### Clear-cut design

A functional design with the minimum weight and dimensions. Easy to commission, easy to operate, and easy to service

#### Modular concept

For easy adaptation to different applications, it can be configured with auxiliary equipment and modular components, such as a seawater cooler. It has four auxiliary power take-offs.

#### Engine control system

Based on a modular concept for low and easy maintenance, this is an internal development using proven Everllence standards of robustness, reliability, and safety.

#### Turbocharger technologies

This is a key area of expertise of Everllence. The single-stage turbocharger is simple and easy to maintain, compared to more complex sequential turbochargers. It was specially developed for the 175D and consequently provides highly efficient performance with a very wide operating range.

# Optimized propulsion solutions

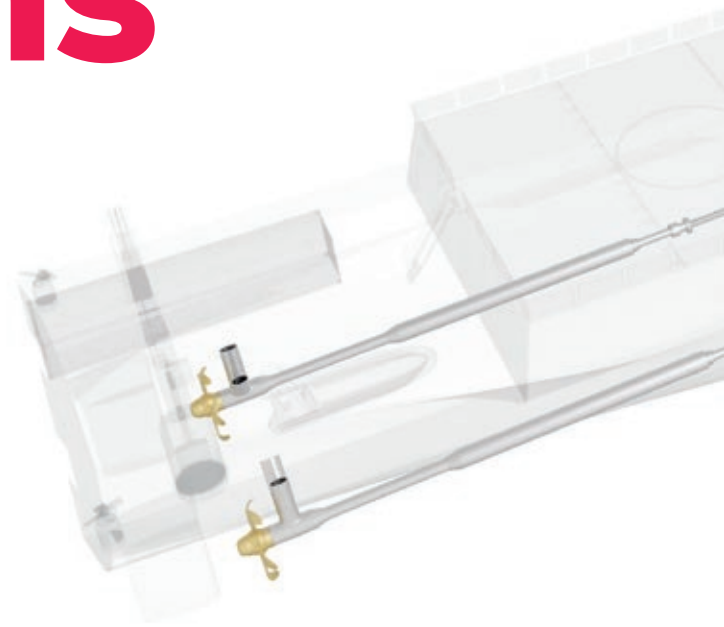

## More than an engine

Everllence has a strong track record in the engineering and servicing of complete propulsion packages (including main engines, electric motors and variable frequency drives, gearboxes, propellers, and propulsion control systems) for navies and coastguards across the globe. We know what you expect: High propulsion performance and operational flexibility with low hydroacoustics.

## Highly efficient propellers

Our propellers can be found on many types of ships – from small coastal cutters or supply and inspection vessels to larger, more powerful OPVs, command support vessels, and frigates.

We offer propeller blades with conventional high-skew profiles for our four- and five-blade series (CPP / FPP), as well as propellers for a shaft power of up to 40 MW. Highly efficient Kappel designs with specially modified fin tips ensure low noise signatures. And this impressive portfolio of products also includes a variety of water-lubricated stern tube systems.

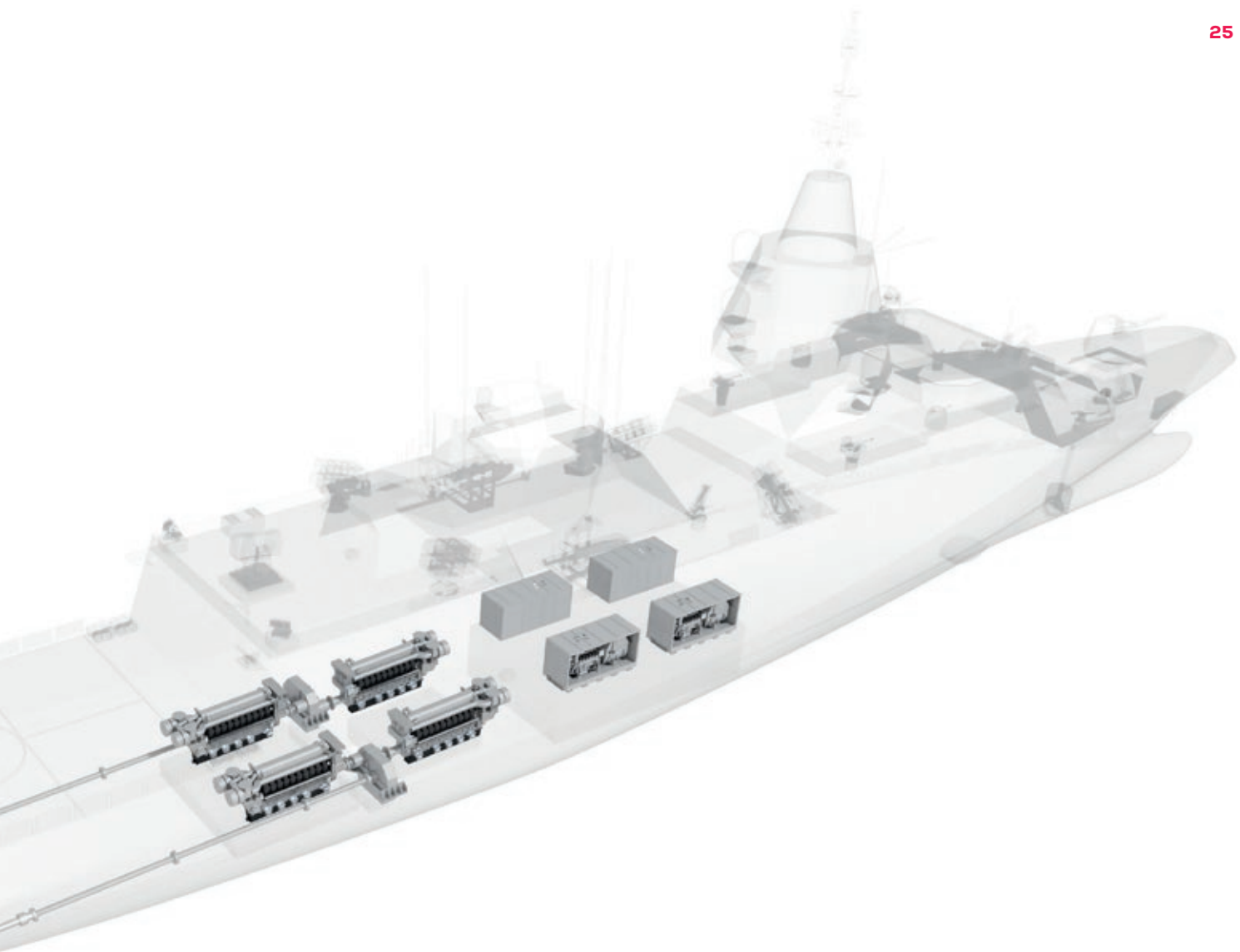

## Benefits of a complete propulsion system

We can create complete solutions for the complex propulsion needs of large ships.

- Everllence engines  
Reliable and high-power
- Everllence ALPHA propellers  
Noise-optimized



**From dock to deep  
sea and on any site  
– your trusted  
service partner**

## Our service portfolio

We offer a full spectrum of services designed to keep your fleet and plants efficient, compliant, and competitive.

- **Genuine OEM spare parts:** Protect your assets with patented, high-quality components manufactured to OEM standards.
- **Long-term service agreements:** Predictable maintenance planning & cost savings tailored to your operational needs.
- **Retrofits & upgrades:** Future-proof your engines and systems for efficiency, emissions compliance, and competitive performance.
- **Technical service & field support:** 24/7 availability to ensure reliability and rapid response worldwide.
- **On-site recovery solutions:** Fast-track repairs to get your equipment back in service with minimal disruption.
- **Remote monitoring & optimization:** Digital solutions to maximize efficiency, safety, and availability of your Everllence machinery.
- **One-stop services with PrimeServ Omnicare:** Consolidate services for your engines, turbines & compressors across major marine and power brands.
- **Everllence PrimeServ Academy:** Get the best qualifications to operate and maintain your Everllence installations.



Our global service network ensures fast response, expert support and maximum efficiency for your engines and systems – helping you stay ahead with reliability you can trust.

### We offer comprehensive service solutions:

**Sales & spare parts:** Genuine OEM parts, expert consulting, and CRM-based support to optimize availability and performance.

**Technical service & maintenance:** Precision repairs, reconditioning and lifecycle optimization for long-term efficiency.

**On-site recovery & field service:** Emergency response and proactive service, wherever you need us.



# 100+

locations worldwide.

## Our global service at a glance

Did you remember to order spare parts? No problem – we did. We also checked lube oil, engine condition, scheduled maintenance and installed updates. As your service partners, we keep your business running smoothly, securing efficiency and safety 24/7, around the world, on-site and online. We're here for what matters most: your peace of mind.

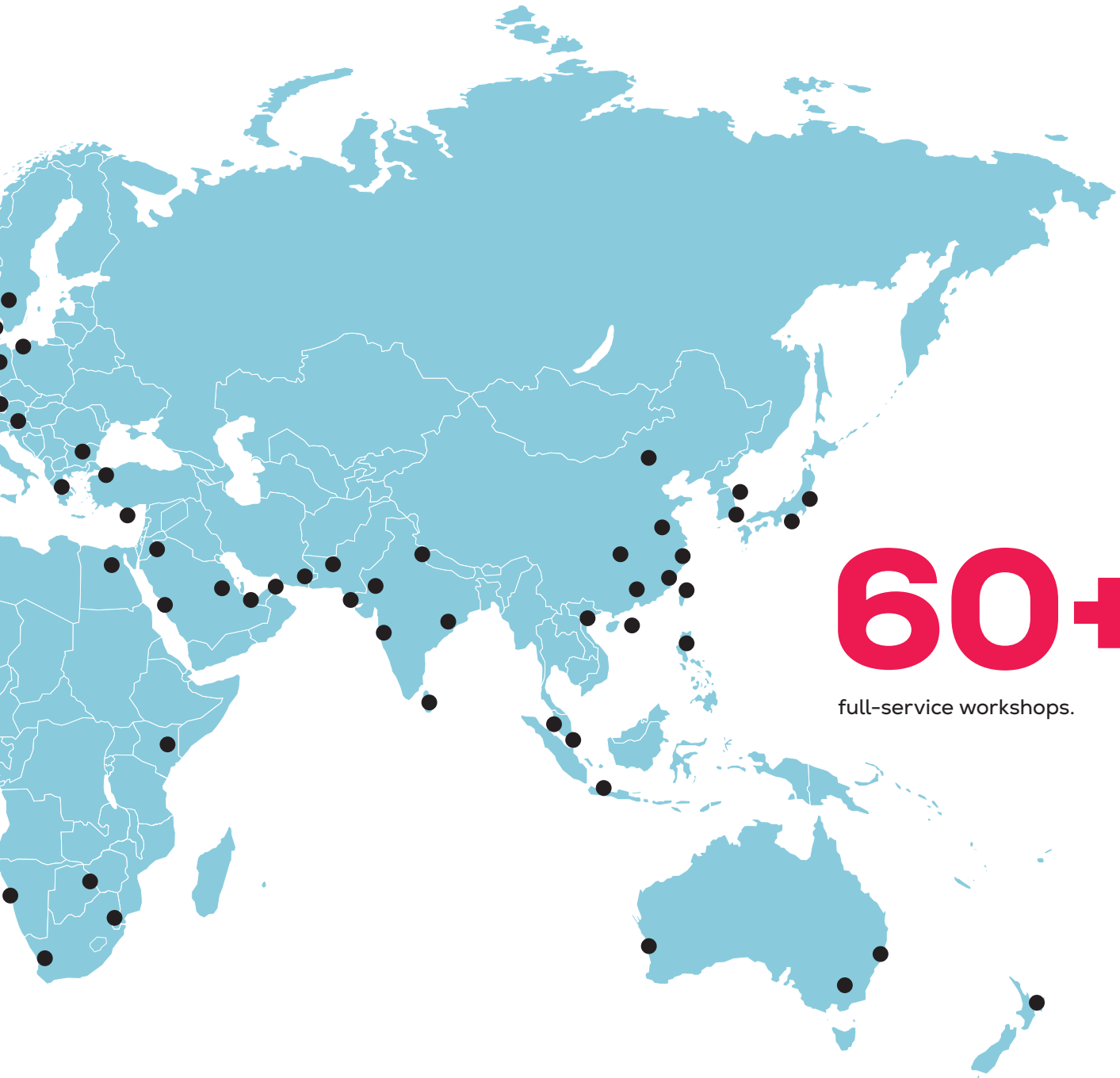

# 60+

full-service workshops.

### Service is digital – service is smarter

Service has evolved, and so have we. Everllence PrimeServ doesn't just help you maintain your assets, we help you future-proof them. As you navigate the shift towards carbon-neutral operations, our digital service solutions ensure that your technology delivers on its promise.

Powered by expert insight, our real-time support and analytics based on remote monitoring keep your equipment performing at peak efficiency – year after year, without interruption. Because service isn't just about fixing problems – it's about preventing them.

### Our location types:

- Sales offices – Spare parts sale & consultation.
- Workshops – Maintenance & repair.
- Flagship service centers – Full spectrum of all services, sales & reconditioning.

**Find out more**

[www.everllence.com/  
services/service-locations](http://www.everllence.com/services/service-locations)

# Making smart connections

## Data & connectivity

Enhanced monitoring and machine analytics, and new standards in security and data privacy are set to lead the way to a better future for your business.

### The digital power of Everllence

Digital fleet management, remote monitoring, and predictive maintenance are already essential to the marine business. At Everllence, we make data work at many levels, connecting engines, ships, services, supply chains, people, and ideas. Our main objective for all marine applications: Greater efficiency.

### Making the most of digitization

Using cutting-edge digital technology allows us to improve performance and minimize down-times. Our remote connections enable live data analysis, ensuring quick, effective solutions. Our energy management system for battery-hybrid propulsion controls the generation, storage, and distribution of power onboard the ship, resulting in maximum efficiency. Multiple digitization initiatives are increasing our understanding of our customers and expanding our offering as well as improving our internal processes and your cost base.



# Everllence

## Everllence

86224 Augsburg, Germany

P + 49 821 322-0

[info@everllence.com](mailto:info@everllence.com)

[www.everllence.com](http://www.everllence.com)

MAN Energy Solutions SE has been renamed to Everllence SE and its products are being rebranded from "MAN" and/or "MAN Energy Solutions" to "Everllence". As this is an ongoing process, any reference to "MAN" and/or "MAN Energy Solutions" is actually a reference to "Everllence".

All data provided in this document is non-binding. This data serves informational purposes only and is not guaranteed in any way. Depending on the subsequent specific individual projects, the relevant data may be subject to changes and will be assessed and determined individually for each project. This will depend on the particular characteristics of each individual project, especially specific site and operational conditions.

Copyright © Everllence  
EVR000058EN-250600, GKM-AUG