

# Everllence

## Next level evolution from PrimeServ

for 32/40 engines

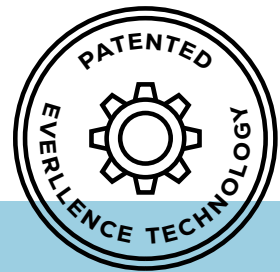

Only available  
from Everllence  
PrimeServ

### The patented Mk3 injection pump sets a new benchmark in reliability.

This new pump generation provides significantly increased reliability and more than doubles the operating time between overhaul for 32/40CD engines.

#### Benefits at a glance

- The most robust design for your reliable engine operation
- Significant reduction of sticking plungers
- Leakage reuse
- State-of-the-art manufacturing
- Increased TBO
- Obliging cost management
- Easy to upgrade
- Manufactured in Germany
- Simple Mk1 to Mk3 conversion
- For all conventional 32/40CD and 32/44K engines

## PrimeServ

# Mk3 injection pump

Next level evolution from PrimeServ

During the new pump's developmental phase, Everlence PrimeServ set its focus on new technological innovations to replace the conventional injection system.

The implementation of a sealing ring inside the pump barrel significantly reduced lacquering and all associated side-effects. Similarly, the new design now avoids the mixture from fuel and lube oil, which enables their re-use and minimises the need for their disposal.

These features are confirmed by extensive Everlence test rig field tests.

Everlence has redesigned the 32/40CD injection pump and established a new, state-of-the-art standard. It is setting a new benchmark in reliability, which is absolutely unique in the market. Everlence manufactures the pump completely in its facilities in Augsburg, Germany.

**Upgrading the preceding Mk1 model to the new Mk3 model can be handled through a simple replacement of the plunger-barrel, the regulation and pump drive. This process can be part of a regular maintenance, which prevents high additional costs.**

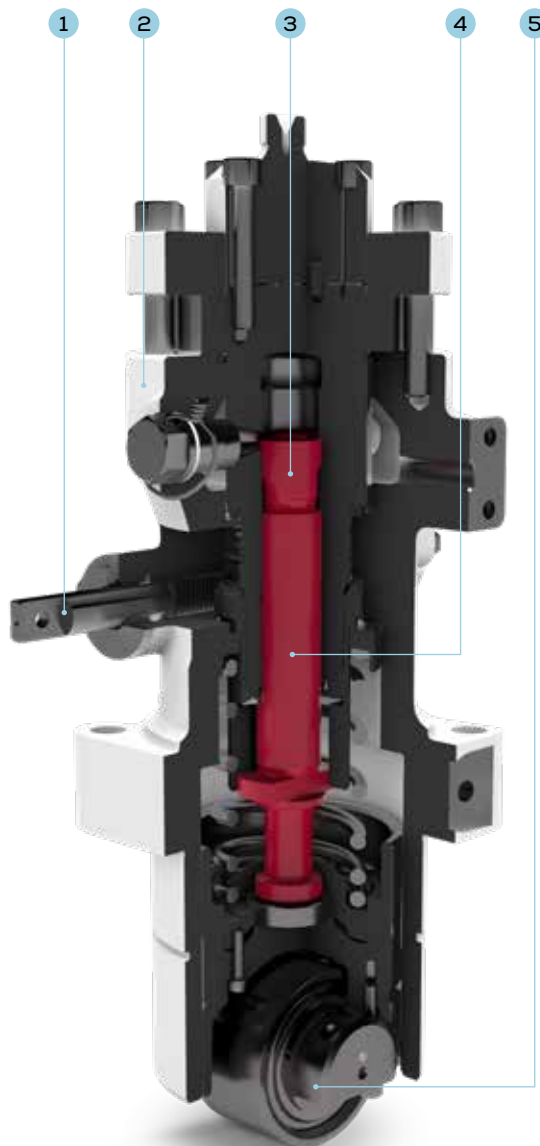

- 1 **New regulating mechanism for the good feeling of a fail-save assembly**
- 2 **Reuse your existing pump housing**
- 3 **Pump element unit with coated plungers produced at highest technological standards**
- 4 **Innovative sealing ring in combination with the patented flushing system to realize the highest robustness and reliability**
- 5 **Drive components with optimized running behavior and latest design**

## Everlence

86153 Augsburg, Germany  
Commercial: + 49 821 322 1799  
Technical: + 49 821 322 1499  
info@everlence.com  
www.everlence.com