

L27/38 fuel system upgrade

By installing the fuel system upgrade and the improved fuel filters in strategically safe areas, Everllence PrimeServ Frederikshavn makes sure that your L27/38 will be updated to today's modern standards.

After the retrofit, your L27/38 engine will fulfill the latest SOLAS regulations, with improved general safety and reliability of your vessel.

The graphic below illustrates how the fuel pipes have been removed from the hot areas of the exhaust piping and turbocharger, and reinstalled in safer areas.

The external fuel piping needs to be changed accordingly, and universal pipes and connectors are included in the upgrade package. Improved fuel filtration units are also included in the package.

Installation of the Fuel system upgrade package requires an Everllence superintendent with expert knowledge of the L27/38 propulsion engine.

If you have maintenance planned in the near future, it would be preferable to order the fuel system upgrade package, and have the Everllence PrimeServ service engineer install it when on board already.

Please contact your Everllence PrimeServ office for more details.

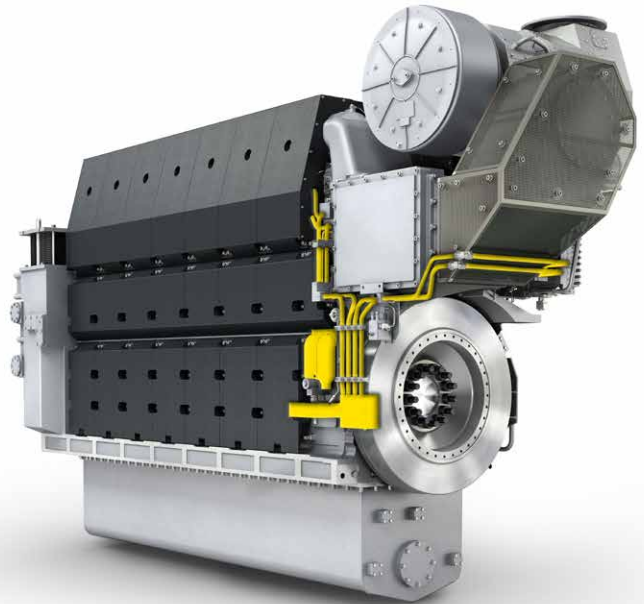

Everllence

PrimeServ

L27/38 fuel system upgrade

Improve your filtration system and increase the equipment's lifetime

Key benefits

- Order now, install when convenient
- Improved filtration
- Increased fuel equipment lifetime
- Reduced risk of fire
- Safe operation

Scope of supply

- Improved fuel filtration units from 50 down to 10 microns depending on existing configuration
- Drip tray and related parts
- Complete set of pipings, valves and connectors

Applicable to

Applicable for L27/38 marine propulsion engines

More information

Contact your local Everllence PrimeServ office for more information about the product and how the upgrade can improve your propulsion configuration.

Everllence PrimeServ

Niels Juels Vej 15
9900 Frederikshavn, Denmark
RetrofitDK@everllence.com
www.everllence.com/services

