

External exchangeable lube oil filter

Several vessel owners have requested a solution for exchangeable filtration for their lubrication system. The paper filter elements will last longer if the separator is in operation, but the system will allow the existing lube oil separator to be out of service.

Everllence has designed and released an insert, replacing the existing built-in backflushing filter with a "filter dummy". This device will lead the oil flow through an external filter cartridge with exchangeable paper filter.

Please contact your Everllence PrimeServ office for more details.

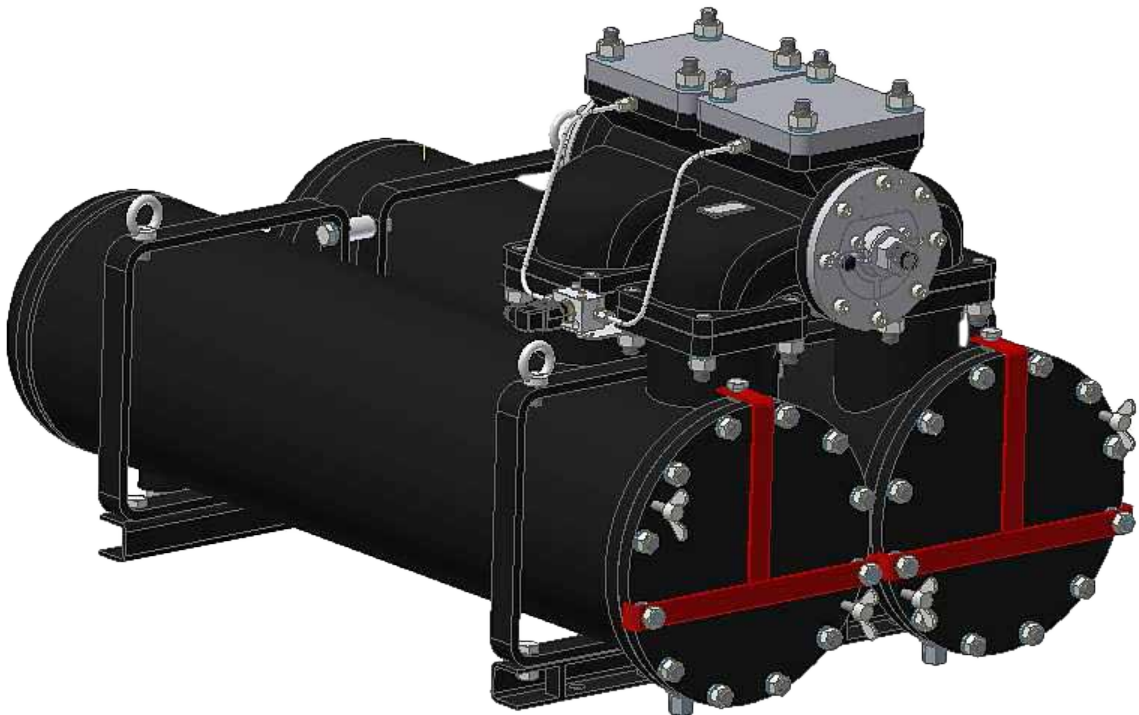

Everllence

PrimeServ

External exchangeable lube oil filter

Easily exchangeable filtration for lubrication system

Key benefits

- Order now, install when convenient
- Easy installation
- Easily exchangeable filter inserts
- Installation can be done while in service, only a few hours out of service is necessary

Scope of supply

- Installation of the new “filter dummy”
- Fitting of external filter
- Piping from the engine to wherever the external filter is installed
- Piping and fitting of the external filter can be done during normal operation.
- This means that the vessel will only be out of service for a few hours, while replacing the existing filter with the “filter dummy” and connecting the piping.
- Piping is not included and is a shipyard/piping workshop task

More information

Contact your local Everllence PrimeServ office for more information about the product and how the upgrade can improve your propulsion configuration.

Everllence PrimeServ

Niels Juels Vej 15
9900 Frederikshavn, Denmark
RetrofitDK@everllence.com
www.everllence.com/services

Applicable to

Applicable for engine type
L27/38

