

Everllence AdaptiVIT

AdaptiVIT dynamically adjusts the injection timing to optimize performance based on the current combustion pressure and emission regulations. This innovation ensures maximum efficiency and compliance under all operating conditions.

General

The engines manufactured by Everllence generally have a manual VIT or an electric VIT, which is deactivated in most cases. The injection timing is constant and usually set to full load. The injection timing can be manually corrected by the operator to set the maximum ignition pressure according to the actual ambient conditions and fuel quality. Our experience in practice shows that most VITs are never touched and the timing remains as it was set when the new engine was commissioned

Basic setting

The electric Variable Injection Timing (VIT) system operates by switching between two fixed positions, which are determined by the engine load.

Depending on the load, the VIT can be in either the EARLY or LATE position. Specifically, when the engine load is less than 87%, the VIT is in the EARLY position, while for loads exceeding 90%, it switches to the LATE position.

This operation is part of the open-loop control system. Once the positions and load-dependent switching points are set, they remain constant during operation, providing consistent performance and fuel efficiency.

Fuel injection pump arrangement

1. Fuel injection pump
2. Crankcase
3. Fuel injection pump casing, pump drive
4. Injection cam follower
5. Eccentric shaft of VIT
6. Camshaft

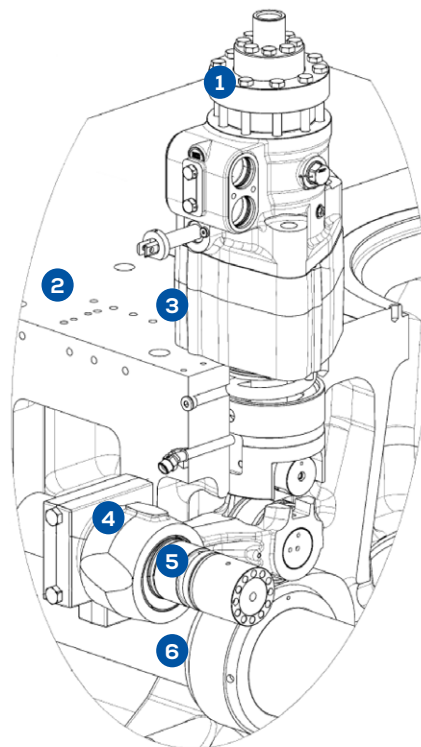

Everllence AdaptiVIT

Availability of AdaptiVIT

Engine range	Installed hardware components	Application
48/60 engine family*	Conventional	Power
51/60 engine family*	Dual-fuel	Marine under development
58/64 engine family*	-	-

*depending on installed hardware components

Control of injection timing in dependence of the combustion pressure and the NO_x emission User

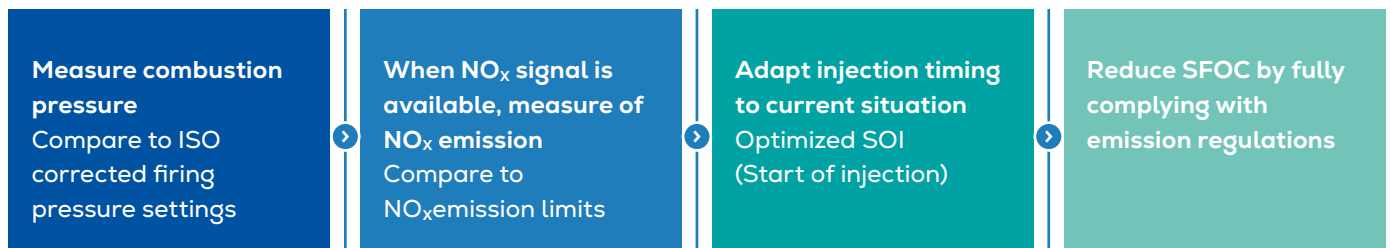

AdaptiVIT in operation

Compensation and optimization of engine performance

Effect 1:

Orange curve (pZ_worn) will be permanently lifted up to original setting (pZ_orig). Dashed curve.

→ **compensation**

Effect 2:

Original dashed curve (pZ_orig) is optimized for operation between 50 and 90 % load (pZ_opt). Light blue curve.

→ **optimization**

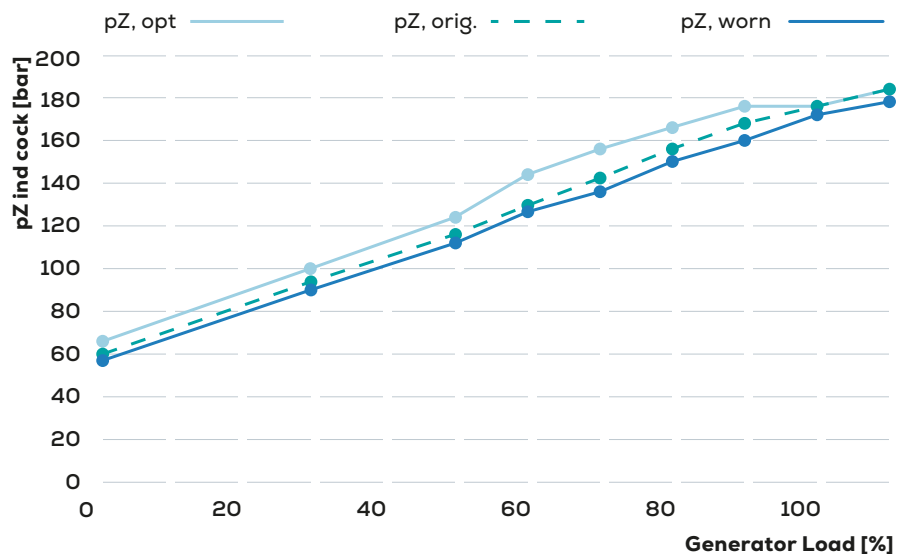

More Information

Contact your local Everllence PrimeServ office for more information about the product and how the upgrade can improve your specific engine.

Retrofit & Upgrades

PrimeServ Retrofit, Denmark
RetrofitDK@everllence.com

Everllence PrimeServ

2450 Copenhagen, Denmark
P + 45 3385 1100
Primeserv-CPH@everllence.com
www.everllence.com