

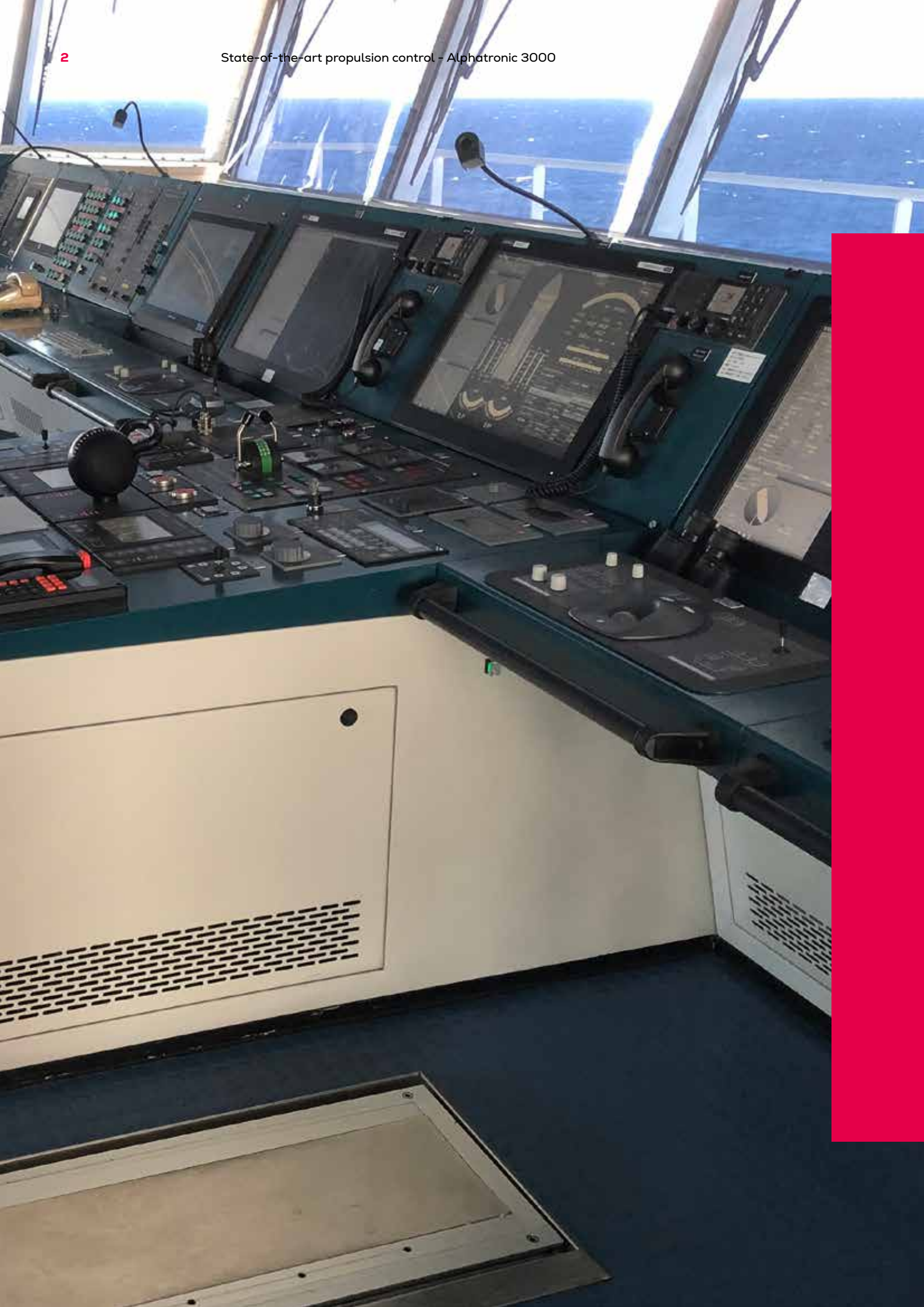

State-of-the-art  
propulsion control

# Alphontronic 3000

## Product Information



# Contents

|  |    |
|--|----|
| Introduction   | 06 |
| Ship's propulsion power – controlled by Alpatronic           | 06 |
| Alpatronic 3000 system description                           | 10 |
| Application overview   | 12 |
| Layout of control stations                                   | 13 |
| Main functions of the control panels                         | 14 |
| Optional functions and equipment                             | 18 |
| Examples of control station configurations                   | 23 |
| Propulsion setup and thrust control                          | 26 |
| Overall system architecture                                  | 30 |
| Interface to propulsion machinery                            | 32 |
| Interface to external control and monitoring systems         | 33 |
| Interfaces to switch board and power management system (PMS) | 34 |
| Propulsion control unit                                      | 37 |
| Local propulsion control system                              | 38 |
| Abbreviations and acronyms                                   | 42 |

# Contents detailed

|   |           |
|---|-----------|
| <b>Alpatronic 3000 PCS – Propulsion Control System</b>                                  | <b>6</b>  |
| <b>Introduction</b>   | <b>6</b>  |
| <b>Ship's propulsion power – controlled by Alpatronic</b>                               | <b>6</b>  |
| Evolution of control  | 7         |
| Accumulated expertise   | 7         |
| Control is crucial  | 8         |
| Inherent Alpatronic advantages  | 8         |
| Advantage as designer of engines, propellers and controls                               | 9         |
| <b>Alpatronic 3000 system description</b>   | <b>10</b> |
| Normal control  | 10        |
| Backup control  | 10        |
| Control from machinery space via telegraph  | 11        |
| <b>Application overview</b>   | <b>12</b> |
| Controllable pitch propeller applications   | 12        |
| Fixed pitch propeller applications  | 12        |
| <b>Layout of control stations</b>   | <b>13</b> |
| Layout for a single propeller plant   | 13        |
| Layout for a twin propeller plant   | 13        |
| <b>Main functions of the control panels</b>   | <b>14</b> |
| Manoeuvre Handle Panels (MHP)   | 14        |
| Propulsion Control Panel (PCP)  | 14        |
| Propulsion Control Panel - touch screen and display examples                            | 15        |
| Telegraph Order Panel (TOP)   | 17        |
| Local Operating Panel (LOP-P) with telegraph  | 17        |
| Emergency Stop Panel (ESP)  | 17        |
| Emergency Clutch-out Panel (ECP)  | 18        |
| Non Follow Up (NFU) control panel for CPP plants  | 18        |
| <b>Optional functions and equipment</b>   | <b>18</b> |
| Speed pilot   | 18        |
| EcoOptimizer  | 20        |
| Synchro phasing   | 21        |
| Pitch setting fine adjustment   | 21        |
| Control of two-step gearboxes   | 21        |
| Control of hybrid packages  | 21        |
| Panama instruments  | 21        |
| Chief engineers cabin   | 22        |
| Power supply  | 22        |
| Manoeuvre printer   | 22        |
| <b>Examples of control station configurations</b>                                       | <b>23</b> |
| Standard control station configurations for single propeller plant                      | 23        |
| Control stations for engine control room  | 24        |
| Standard control station configuration for twin propeller plant                         | 24        |
| Standard bridge wing control station configuration for twin propeller plant             | 24        |
| Standard control station configuration for single propeller as twin-in single-out plant | 25        |

|  |           |
|--|-----------|
| <b>Propulsion setup and thrust control</b>                             | <b>26</b> |
| Propulsion set up  | 26        |
| Transfer of responsibility   | 26        |
| Electrical shaft lever synchronization                                 | 26        |
| Thrust control modes   | 26        |
| Combinator curves  | 26        |
| Protection of propulsion machinery                                     | 29        |
| Barred speed range   | 29        |
| <b>Overall system architecture</b>                                     | <b>30</b> |
| Power distribution   | 30        |
| Power supply   | 30        |
| Networks architecture  | 31        |
| Cabling  | 31        |
| <b>Interface to propulsion machinery</b>                               | <b>32</b> |
| Engine interface: Engine start/stop, speed control and load control    | 32        |
| Engine interface: Engine safety shutdown and load reduction            | 32        |
| Gear interface: Power transmission and clutch control                  | 32        |
| Propeller interface: Propeller pitch and shaft brake control           | 33        |
| <b>Interfaces to external control and monitoring systems</b>           | <b>33</b> |
| Interface to ship alarm system   | 33        |
| Interface to voyage data recorder (VDR)                                | 33        |
| Interface to GPS for Alphatronic 3000 speed pilot and master clock     | 33        |
| Interface to DP and joystick control system                            | 33        |
| <b>Interfaces to switch board and power management system (PMS)</b>    | <b>34</b> |
| Interface to power take off from shaft generator (PTO)                 | 34        |
| Interface to power take home (PTH)                                     | 35        |
| Interface for power boost  | 36        |
| Interface to fire fighting pump  | 36        |
| Interface to a dredge control and monitoring system                    | 36        |
| Interface for automatic propulsion power setup (prepare/end operation) | 36        |
| <b>Propulsion control unit</b>   | <b>37</b> |
| <b>Local propulsion control system</b>                                 | <b>38</b> |
| LPCS - system design   | 38        |
| Local operator panel for the propeller (LOP-P)                         | 39        |
| Local operator panel for the engine (LOP-E)                            | 39        |
| Alarm and monitoring sensors from the propeller                        | 39        |
| Control of CPP servo oil pumps   | 39        |
| Cable plans  | 39        |
| Commissioning  | 40        |
| Instruction manual   | 40        |
| PrimeServ ACADEMY training   | 40        |
| <b>Abbreviations and acronyms</b>                                      | <b>42</b> |

# Alpatronic 3000 PCS

## Propulsion Control System

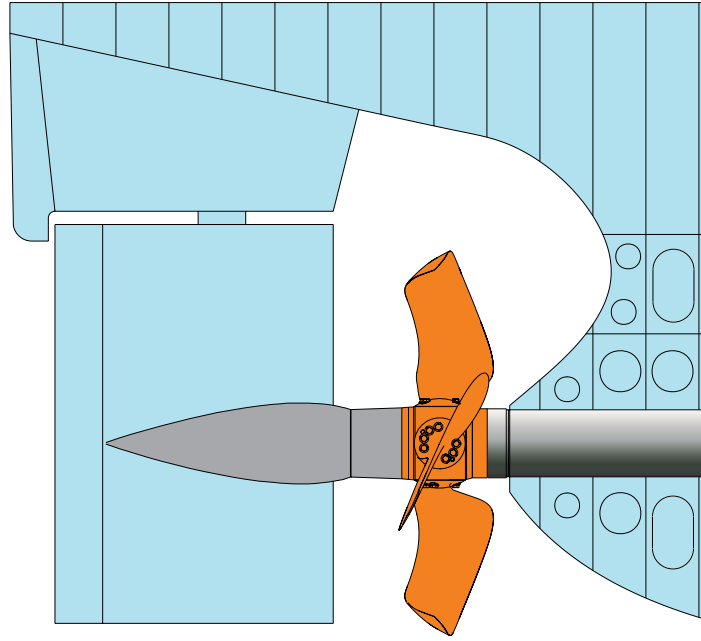

### Introduction

This 'Product Information' publication is intended as a guide during project planning and lay out of the Alpatronic 3000 Propulsion Control Systems.

It describes the system in general, the standard control elements and options available for tailoring a propulsion control system to the individual vessel, the propulsion system configuration, the operating modes and the manoeuvring stations.

Our product range is constantly under review, being developed and improved according to present and future requirements and conditions. We therefore reserve the right to make changes to the technical specifications and data without prior notice.

Alpatronic 3000 Propulsion Control Systems are usually specified for Propellers & Aft Ship systems based on Alpha controllable pitch and Alpha fixed pitch propellers.

### Ship propulsion power controlled by Alpatronic

Everllence launched the first Alpha CP propeller as part of a propulsion system in 1902. It was a complete package including engine, clutch, shafting and propeller.

All control and manoeuvre actions were carried out in accordance with the standards of that time, which meant locally by hands-on.

Fig. 1: Two-stroke low speed propulsion package  
(Everllence B&W 6G45ME-C-9.5-GI-TII engine,  
shaft clutch, shaft alternator, VBS1350 CP propeller)

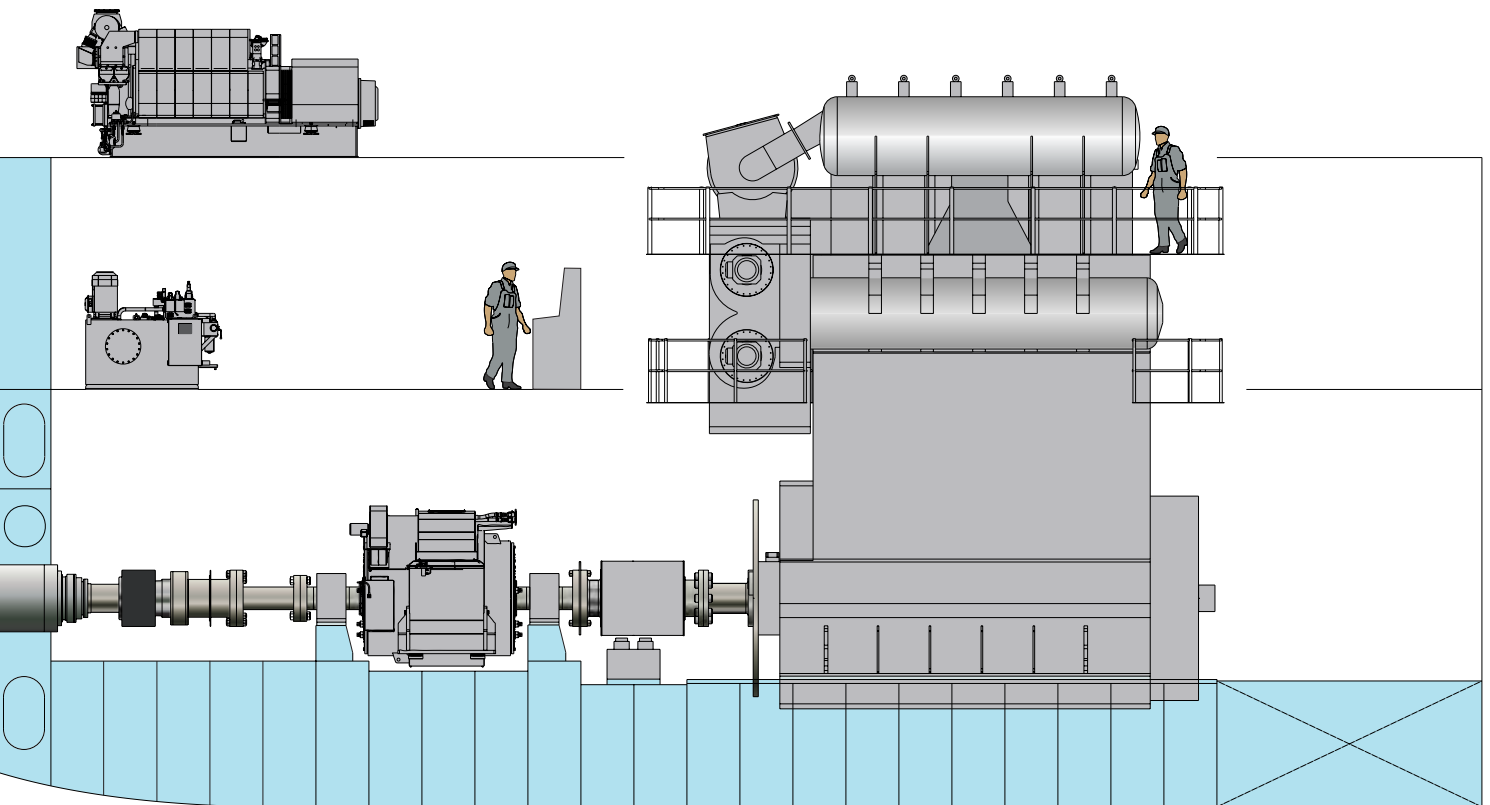

### Evolution of control

In view of the following decades of development, not only in the physical dimensions of the ships, but also in the propulsion equipment itself, – the control and manoeuvre actions shifted from local to remote by means of different intermediates.

These intermediates developed from mechanical push/pull rod systems, flexible cable systems, pneumatic systems, and up till today's electronic and computer controlled systems.

Year by year, both the operator and the equipment itself required more and more sophisticated control systems for economical cruising at various operating modes, engine load sharing, redundant propulsion power via PTI/PTH, hybrid combinations, etc.

The latest version of the Alpatronic generations described here is type Alpatronic 3000 PCS. Abbreviations and acronyms in this paper are listed and explained on page 39-40.

### Accumulated expertise

More than 7,500 propellers and propulsion packages have entered service – operated by various types of control systems.

Today's standard for Alpha propellers and propulsion packages from Everllence is the well-proven Alpatronic generation – now with the state-of-the-art Alpatronic 3000 PCS. Since Alpatronic's 1982-introduction, more than 3,000 systems have been delivered for a wide range of propulsion package combinations with two-stroke engines and propellers, four-stroke engines, reduction gearboxes and propellers for an output range up to 60,000 kW.

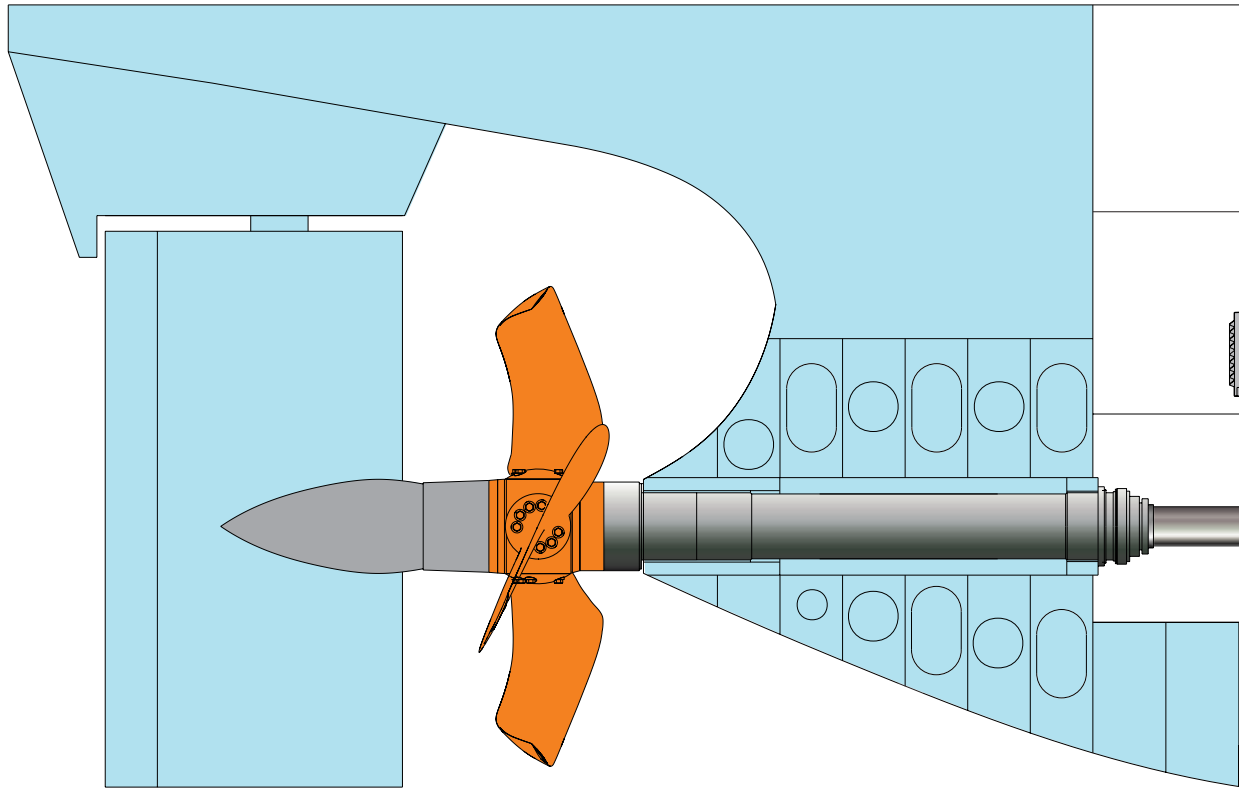

### Control is crucial

In the process of projecting and estimating propulsion systems, the associated control system is a 'soft' item frequently handled with less attention. The propulsion control system is often regarded as a necessary auxiliary element that just follows the primary propulsion elements.

Fuel consumption, emission levels, performance and propulsion efficiency of the 'hard' engine and propeller elements are, however, undermined – without the correct matching and performing control system!

### Inherent Alpatronic advantages

A tailored Alpatronic 3000 control system ensures:

- Safe control of the propulsion plant and reliable manoeuvring of the ship
- Economic operation thanks to optimized engine/propeller load control
- Quick system response and efficient CP propeller manoeuvrability
- Quick reversing and possible trolling control for efficient FP propeller manoeuvrability
- Load changes controlled in such a way that the governor always keeps the engine speed within the range required, and thus prevents e.g. blackout during shaft alternator operation
- Good long term engine performance thanks to overload protection
- Thermal protection of the engine via controlled running-up programmes
- Torsional protection of engine and shaft system via quick-passing through barred/critical speed ranges
- Environmental friendliness thanks to balanced manoeuvring dynamics during acceleration with minimal smoke emission
- Flexibility and individual customization due to modular system principles
- Project support, simple installation procedures and safe commissioning

Fig. 2: Four-stroke medium speed propulsion package (6L32/44CR engine, reduction gear with shaft alternator, VBS 940 CP propeller)

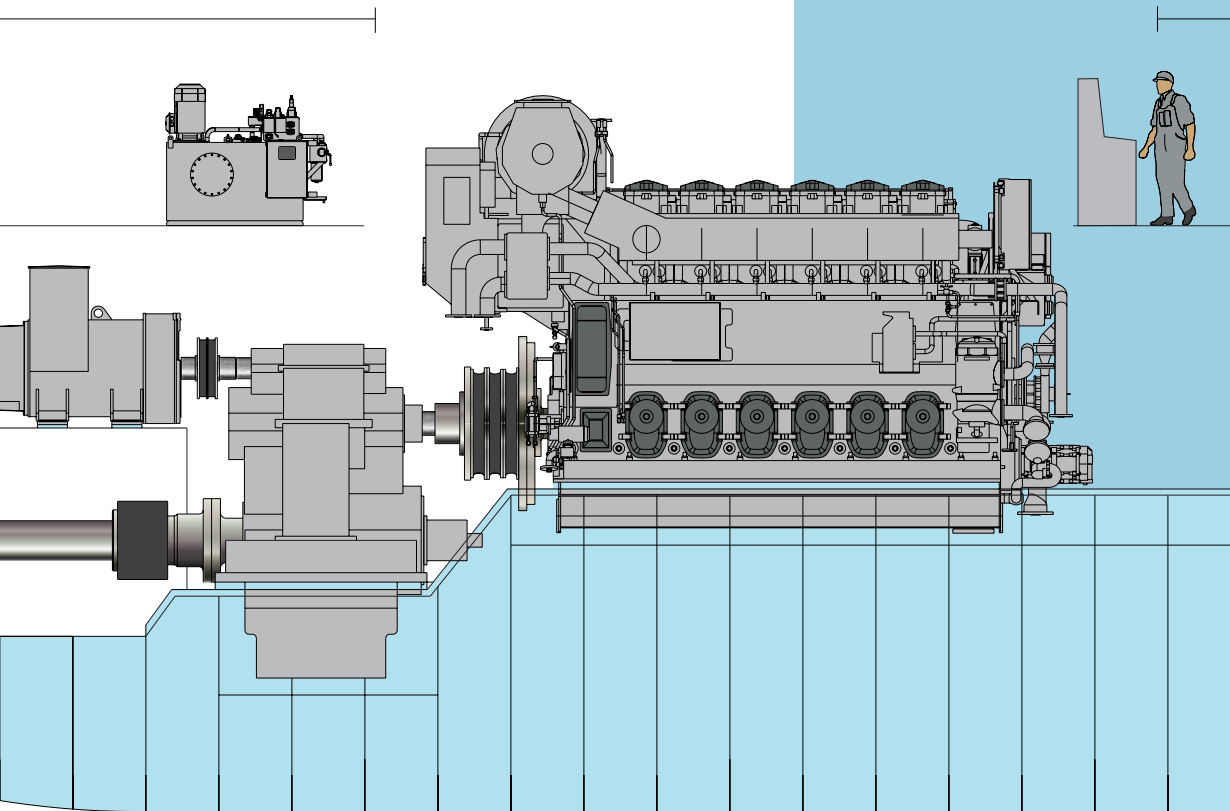

- User-friendly operator functions due to logic and ergonomic design of control panels, handles and displays
- Minimal service and maintenance requirements
- Overall system reliability and durability
- Type approval by all major classification societies

#### **Advantage as designer of engines, propellers and controls**

In general, the control system acts as the central propulsion package 'brain' element, being in charge of the remaining propulsion package elements, their coherence and their interaction with one another. Everllence embrace and master all these products.

The Alphasonic 3000 product is approved for all engine types. For the two-stroke series an interface is available for the Engine Control System (ECS) for ME, ME-G, and ME-B engines.

For the four-stroke medium speed series a standardized interface is available for the SaCoSone control and safety system, and for the new 175D high speed series an interface to SaCoS 5000 is available for all applications with FPP, CPP and waterjet.

The key design advantages gained with the Alphasonic systems, accumulated during 42 years of service – are extensive knowledge on:

- All propulsion package elements, ship and system integration
- Two-stroke and four-stroke engines, fuel consumption and emissions
- CP and FP propellers, manoeuvrability and hydrodynamic behavior
- Overall operating economy, long term performance, load characteristics and system dynamics – and that makes all the difference.

## Alphatronic 3000 system description

The system offers three levels of propulsion control:

- Normal control with automatic load control
- Backup control from bridge and ECR
- Independent telegraph system for communication from bridge to machinery space.

The system is based on a modular panel design concept to elegantly fit any ship console layout. A configurable touch screen in the propulsion control panel meets a wide range of customer specific functions.

The control system fulfils requirements for propulsion plants with two- or four-stroke engines connected to controllable pitch or fixed pitch propellers. It is available for high-, medium- and low-speed engines in a wide range of diesel-mechanical, hybrid or diesel-electric propulsion setups for single, twin and multi propeller plants.

Basically, the Alphatronic 3000 system is a remote control system intended for control of the ship's propulsion machinery. An engineer onboard the ship uses the system for setup and monitoring of the propulsion power. Setup of propulsion power is done manually from the touch screen in the propulsion control panel on a propulsion control station.

The system interfaces with the propulsion machinery via transducers and actuators located on the machinery.

When propulsion power is available, an operator on the navigating bridge takes over the responsibility and uses the system for control of the propeller thrust.

To fulfil the requirements for different kinds of manoeuvrability for the ship and the requirements for independent means for communicating orders from the navigating bridge to the machinery space, a number of control levels are available for control of the longitudinal thrust.

Thrust commands might come from an external **coordinated control** system (DP system or Joystick system) or from a propulsion control station on the bridge.

The thrust command can be performed in different control levels from the propulsion control station, either as **Normal control** from the control lever in a handle panel, as **Backup control** orders from one of the display panels, or indirectly via **Telegraph orders** from the navigator on the bridge to an engineer in the machinery space.

### Normal control

The system architecture for normal propulsion control is based on a central PCS unit (mounted in a control cabinet located in the machinery space). The PCS unit is in normal control handling transfer of control responsibility, setup of propulsion power, thrust commands and propulsion overload protection.

Communication to the control panels on the bridge and in the ECR is done via a duplicated panel network to the display panels.

Other panels on the control location are communicating via a location bus on the display panel. The interface to the propulsion machinery is hardwired input/outputs in the PCS unit tailored to the individual engine, gear, electro motor and propeller incorporated in the individual propulsion plant.

### Backup control

The local propulsion control system (LPCS) is a redundant control and monitoring system comprising two independent control panels for control and monitoring of the propeller shaft line.

One control unit is primarily used for **remote** control and monitoring of the shaft line, and the other control panel is primarily used for **local** control and monitoring of the shaft line.

The panel used for local control comprises a telegraph and backup control bus connected to the propulsion control panels and the telegraph panels on the bridge and in ECR.

The propulsion control panels are able to operate independently of the propulsion control unit (PCU). If backup control is selected on a propulsion control panel, the propeller thrust can be controlled independently of the PCU via the telegraph and backup control bus to the LPCS.

**Control from machinery space via telegraph**

When the responsibility for control of the thrust is transferred to the machinery space (engine control room or engine room) the independent telegraph panels can be used for communication of thrust orders from the navigating bridge to the machinery space.

The engineer is able to control the thrust independently of the control level selected

(normal, backup or local control) and according to the telegraph orders from the bridge.

In **normal** control level, the engineer responds to the telegraph orders with thrust commands on the handle panel in ECR. In **backup** control level, the engineer responds to the telegraph orders with backup thrust commands on the propulsion control panel in ECR.

In the **local** control level from the engine room, the engineer responds to the telegraph orders on the local operator panel for the propeller (LOP-P) in the engine room, and sets on the same display menu on the LOP-P the thrust commands according to confirmed telegraph orders.

Fig. 3: Control system architecture – two-stroke propulsion package example with CP propeller

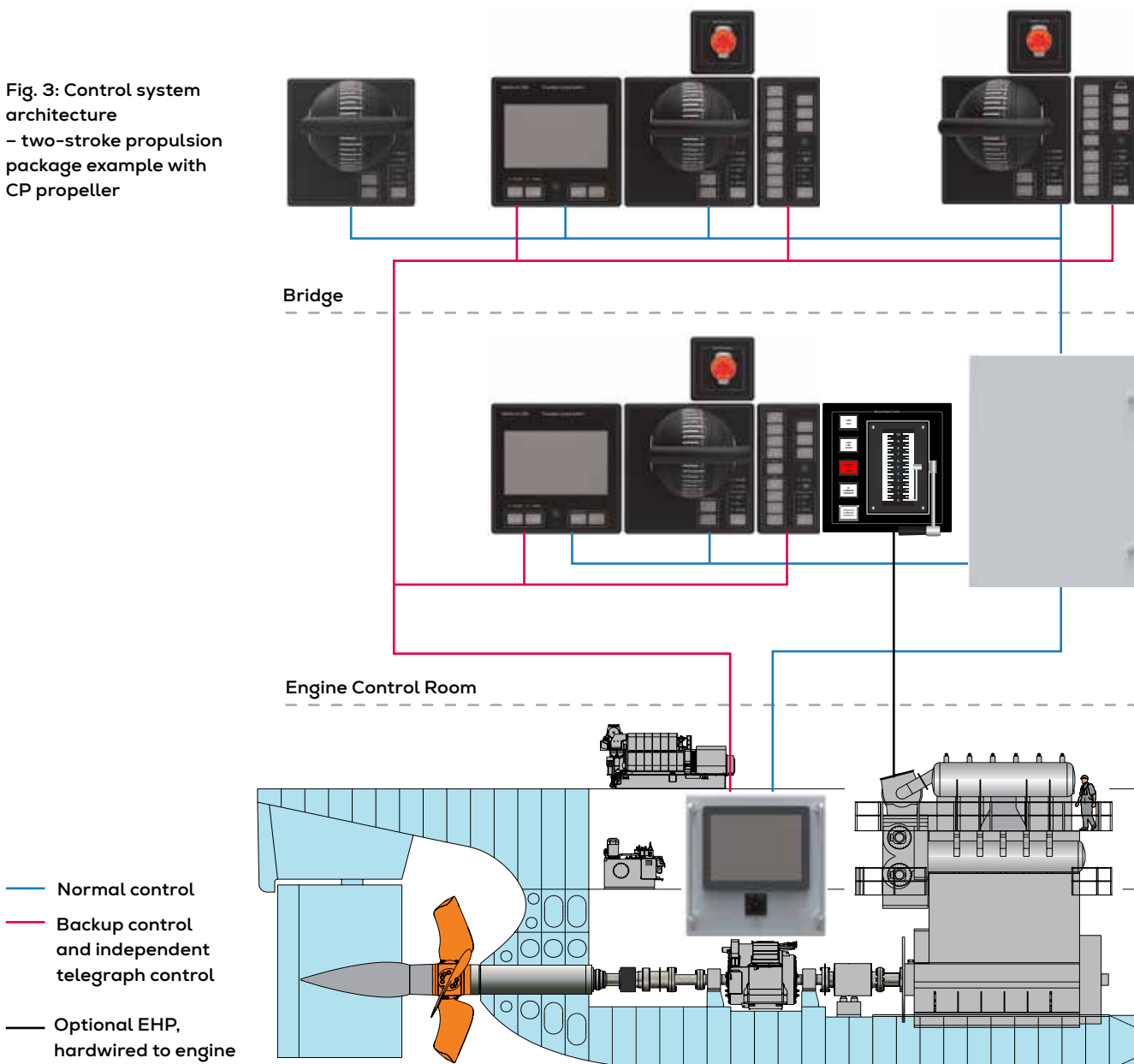

## Application overview

### Controllable pitch propeller applications

Four-stroke medium speed engine applications with a reduction gear comprising no or several clutches can be controlled by the Alphatronic 3000 system in single and twin propeller installations.

Further, propulsion lines with a twin-in single-out reduction gear can be controlled by the Alphatronic 3000 system in single and twin propeller installations. The system comprises remote start and stop of the engines from the display panels and control of engine speed from the handle panel. The engine clutches can be controlled individually from the display panels and controlled in common from the handle panels.

Applications with non-reversible two-stroke low speed engines can be controlled by the Alphatronic 3000 system in single and twin propeller installations. The system comprises remote start and stop of the engines from the display panels and control of engine speed from the handle panel.

### Fixed pitch propeller applications

Applications with four-stroke medium speed engines connected to a reversing gear can be controlled by the Alphatronic 3000 system in single and twin propeller installations.

The system will comprise remote start and stop of the engines from the display panels and control of gear clutches and engine speed from the handle panel. For high-speed vessels, interlocks will restrict unintended manoeuvre changes related to load changes on one of the two shaft lines.

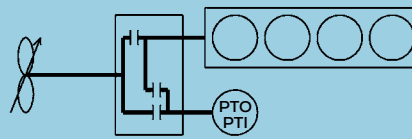

Four-stroke engine. Single and twin propeller plants with CPP. Reduction gear with clutches for PTO, PTH and PTI power boost.

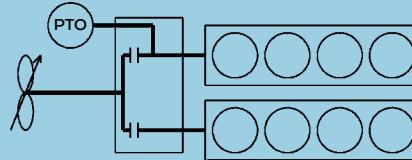

Four-stroke twin-in single-out shaft line. Single and twin propeller plants with CPP. Twin-in single-out reduction gear with primary or secondary PTO. Diesel-mechanical, hybrid or diesel-electric propulsion systems.

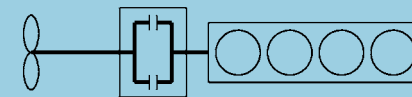
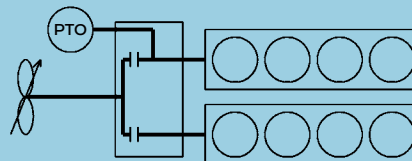

Four-stroke engine. Single and twin propeller plants with FPP. Reversible gear and fixed pitch propeller, or water jets.



Two-stroke non-reversible engine. Single and twin propeller plants with CPP. Plants with two-stroke engine and Alpha CPP.



Two-stroke reversible engine. Single and twin propeller plants with FPP. Plants with two-stroke engine and Alpha FPP.

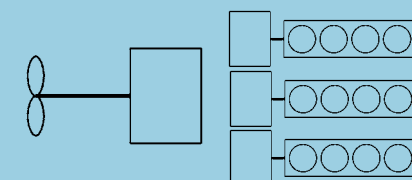

Diesel-electric propulsion plants with FPP and CPP. Plants with Alpha FPP or CPP configurations.

Fig. 4: Application examples for the Alphatronic 3000 propulsion control system. Multiple alternatives are available.



## Main functions of the control panels

### Manoeuvre Handle Panels (MHP)

The Manoeuvre Handle Panel (MHP) is the primary control device for the main propeller. The panel is always located on the ship's bridge, normally also in the ECR and optionally on the bridge wings and aft bridge.

A control station will comprise one, and only one, Manoeuvre Handle Panel in a suitable version for the actual propulsion plant. The stepper motor(s) of the MHP is built into the spherically shaped handle body - requiring very limited installation space and console depth. On CPP plants, the lever will control the thrust and thrust direction via speed and pitch setting.

The CPP clutch buttons are excluded on CPP applications without a clutch. For medium speed engines with a reversible gear and FPP, the control of the clutches to ahead/astern is included in the lever, which can also include a possible trolling function for coupling control during manoeuvring and slow steaming. For two-stroke reversible engines with FPP, reversing and engine start/stop control is incorporated in the lever.

The single-handle panel is used for single propeller applications, and the double-handle panel is used for twin-propeller plants. The double-handle version is for independency of the two shaft lines divided into two separate electric circuits.

All handles comprise a stepper motor for alignment (electric shaft system) of the levers according to the commands from the lever in command.

### Propulsion Control Panel (PCP)

The PCP comprises a touch screen with soft keys for handling transfer of control responsibility and setup of propulsion power.

In addition to propulsion setup the display is handling the general monitoring and alarm for the propulsion control system as well.

The control function related to 'shutdown' and 'load reduction' from the engine safety system is also available in the display panel. One PCP per propeller shaft must be available on the bridge control location and in the ECR.

The PCP provides two levels of control. 'Normal control' with thrust commands from the selected manoeuvre handle and 'Backup control' with thrust commands from a soft key menu in the display panel.

The PCP can be selected for all bridge control stations, if setup of propulsion power is necessary on other bridge control stations than the main control station on the bridge centre.



Fig. 7: Single-handle version - MHP - for CPP



Fig. 8: Double-handle version - MHP - for CPP

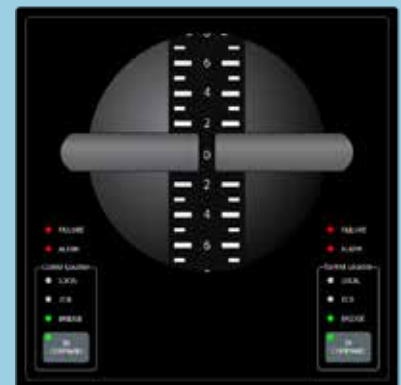

Fig. 9: Double-handle version - MHP - for FPP



Fig. 10: Propulsion Control Panel - PCP - for CPP

**Propulsion Control Panel  
– touch screen and display examples**

The Propulsion Control Panel (PCP) comprises a 7-inch touch screen. The functions and displays are tailor made to the specific engine and propulsion system applications.

The main menus shown here are some examples for CP and FP propeller propulsion plants. Other main menus, however, are available and can be tailored and implemented on request.



Fig. 12: BackUp Control



Fig. 11a: Home screen – single CP propeller plant



Fig. 13: Control Location transfer



Fig. 11b: Home screen – twin high-speed engine plant



Fig. 14: Example of Menu selection



Fig. 15: Engine Start / Stop



Fig. 18: CPP Pitch Control



Fig. 16: Clutch Control



Fig. 19: Shut Down and Load Reduction

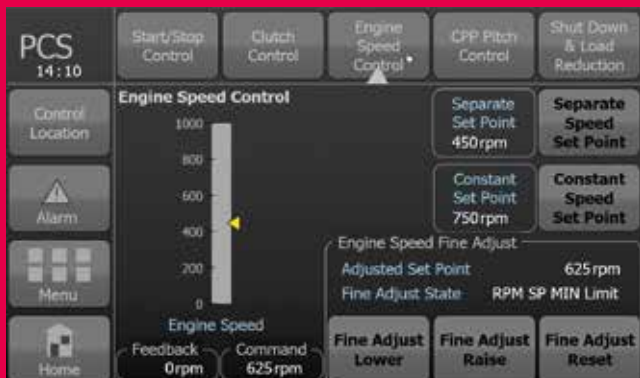

Fig. 17: Engine Speed Control



Fig. 20: Speed Pilot

### Telegraph Order Panel (TOP)

The Telegraph Order Panel is operating totally independent of the propulsion remote control system. According to SOLAS requirements, at least one telegraph panel per propeller shaft must be available on the bridge control location and in the ECR. However, the telegraph panel can be placed on any bridge control station where the telegraph order communication is expected to be relevant.



Fig. 21: Telegraph Order Panel – TOP

The telegraph can be used for independent order communication from the bridge to machinery space. In the ECR, control telegraph orders are available in control level 'Normal' and 'Backup'. In local control from the engine room, the telegraph panel is connected to the local

operating panel (CPP only) used for telegraph order acknowledgement and setting of corresponding local thrust commands.

### Local Operating Panel (LOP-P) with telegraph

The LOP-P for the propeller is located in the engine room close to the local operator panel for the engine. In addition to the local control and monitoring functionality for the propeller system, the panel is used for telegraph order acknowledgement.



Fig. 22: LOP-P with telegraph receiver and propeller pitch control

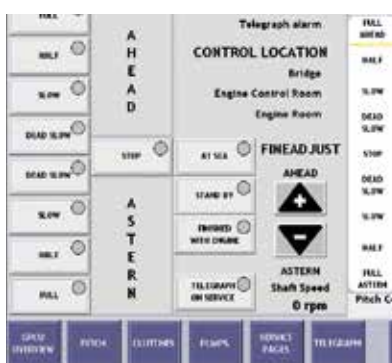

Fig. 23: Zoom in on the LOP-P display with more sub-menus available – as for example for monitoring of bearing temperatures in stern tube and intermediate shaft line

### Emergency Stop Panel (ESP)

The propulsion power Emergency Stop Panel is operating totally independent of the propulsion remote control system. According to regulatory, at least one Emergency Stop Panel per propeller shaft must be available on the bridge control location and in the ECR.

For safety reasons, it is recommended to incorporate an Emergency Stop Panel on all control stations.

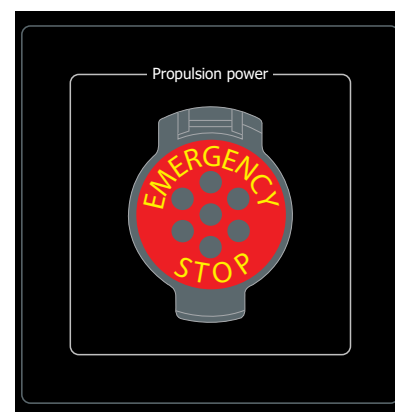

Fig. 24: Emergency Stop Panel – ESP

### Emergency Clutch-out Panel (ECP)

The Emergency Clutch-out Panel for geared four-stroke plants is an alternative to the Emergency Stop Panel. The Emergency Clutch-out Panel is connected directly to the LPCS for safety clutch-out of all gear clutches connected directly to the propeller shaft.

This independency of PCS allows the Emergency Clutch-out Panel to be used as an alternative to the Emergency Stop Panels.

The Emergency Clutch-out Panel can also be delivered as an addition to the Emergency Stop Panels, but the intention is that the Emergency Clutch-out Panel is used as a replacement for the Emergency Stop Panel.



Fig. 25: Emergency Clutch-out Panel – ECP

The advantage may be that gear/propeller can be clutched out while still maintaining engine power and electrical output from a shaft alternator.

A combination with an Emergency Clutch-out Panel on the bridge and an Emergency stop button in ECR is also allowed.

### Non Follow Up (NFU) control panel for CPP plants

In addition to the three standard levels 'Normal control', 'Backup control' and 'Local control', a fourth control level may be delivered if requested by the customer.

An Non-Follow Up control panel is available for hardwired pitch control from the bridge and ECR.



Fig. 26: Non Follow Up control panel – NFU

### Optional functions and equipment

A large number of specific control, monitoring and display features are available or can further be customized into the Alphatronic 3000 system.

#### Speed Pilot

An optional Speed Pilot feature is available with connection to the ship's GPS system for 'speed over ground' (SOG) input. The Speed Pilot optimizes the voyage planning and operational speeds e.g. for pulling, trawling, steaming and convoy sailing – with fuel saving potentials of up to 4%. The Speed Pilot is ideal for maintaining constant ship speed – even in shaft generator mode with varying electrical loading.

The Speed Pilot assists the navigators' approach to optimal route planning and ship speed control. This function will relieve the operator from constantly monitoring the speed of the vessel and constantly changing the thrust order at the handle when external forces such as wind, current and waves are changing the ship speed along its route.

The Speed Pilot is regarded as a control station. When selected, the Speed Pilot will thus appear from the screens as 'Control Station in Command'. The thrust mode of the system is not changed when selecting the Speed Pilot.

In order to be able to judge the Speed Pilot performance, the system has a graphical trend function and possibilities of adjustment from the propulsion control panels.

Fig. 26a: Speed Pilot – display views for setting and controlling the ship speed.

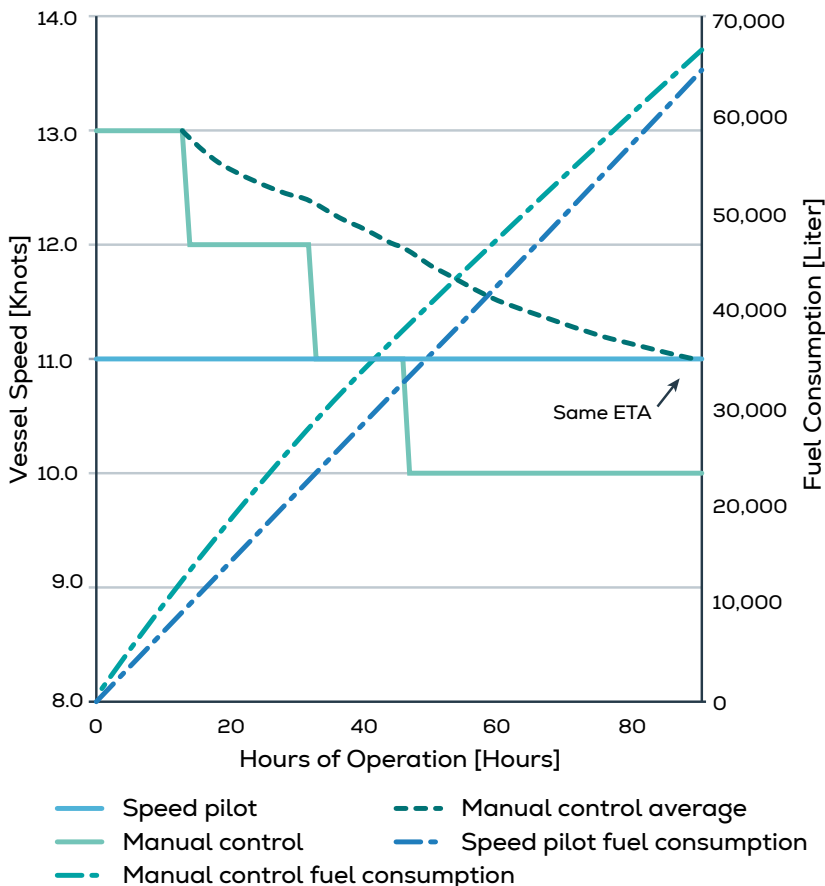
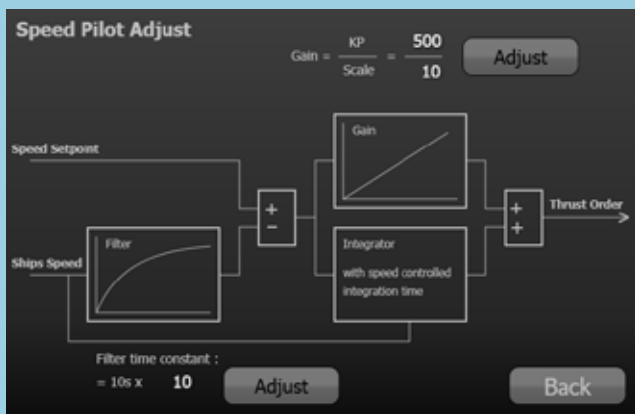
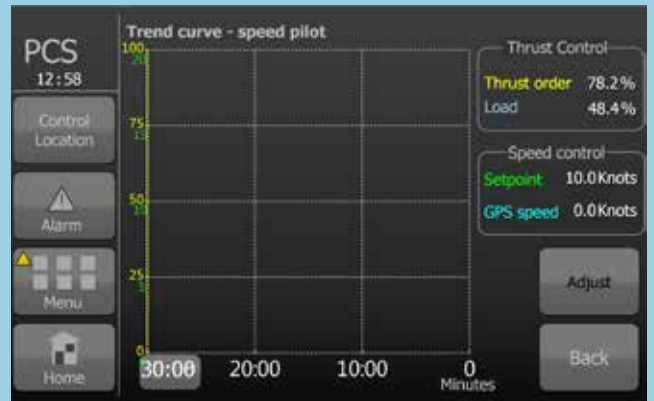

Fig. 26b: Manual control versus Speed Pilot: Real life fuel savings of up to 4% have been demonstrated on a sea voyage of 1,000 Nautical Miles with a 2 x 8L27/38 powered AHTS vessel

### EcoOptimizer

As part of our continuous development and constant strive to improve design, operational performance and economy – our fuel-saving EcoOptimizer concept can be offered for propulsion solutions with Alpha Controllable Pitch Propellers.

The EcoOptimizer benefits are:

- Fuel saving potential up to 6% compared to standard combinator curves
- Propulsion system optimization
- Overall economy optimization and operational mode setting considering ship speeds, propeller pitch settings and individual main engine SFOC maps
- Performance and consumption visualized via Alpatronic 3000 propulsion control display.

Optimum – the EcoOptimizer is combining the best of two worlds. Propeller optimum operation: A combinator curve is determined from the requirement of having an optimum propeller efficiency at all ship speeds – as shown in Fig. 27 by the passing of the blue curve through the minimum or 'valleys' of the constant ship speed lines.

The determination of the combinator curve, solely based on the propeller characteristics, does not ensure that the main engine is operating according to its optimum performance, fuel-wise.

Engine optimum operation: Following the same principle as for the optimum propeller operation, a similar optimum fuel oil curve can be determined. For each constant ship speed, an optimum point is given with respect to achieving the lowest SFOC.

A typical engine fuel map is shown in Fig. 27a with the specific fuel oil consumption figures (SFOC) given as constant lines.

Where the blue curve in Fig. 27 will ensure that the propeller has the highest efficiency, the red curve will ensure that the engine will achieve the lowest SFOC value for each ship speed.

The overall optimum operation: Overall, the operation on either of the curves will not result in the lowest possible fuel consumption (e.g. measured in kg/hour or tons/day).

The total fuel oil consumption is determined by the product of the power required for propelling the ship and the corresponding SFOC of the main engine.

A comparison of the runs of the optimum propeller and engine curves will reveal that they do not coincide. That is, one curve is optimum for the propeller and one for the engine.

Thus, if for each ship speed the product of the power and SFOC are calculated along each constant ship speed, the optimum setting of the propeller shaft speed and propeller pitch setting can be determined and used to generate the third and final EcoOptimizer (green color) curve that will result in minimum fuel oil consumption (FOC).

Fig. 27: Optimum propeller (Efficiency), engine (SFOC), and EcoOptimizer (FOC) curves

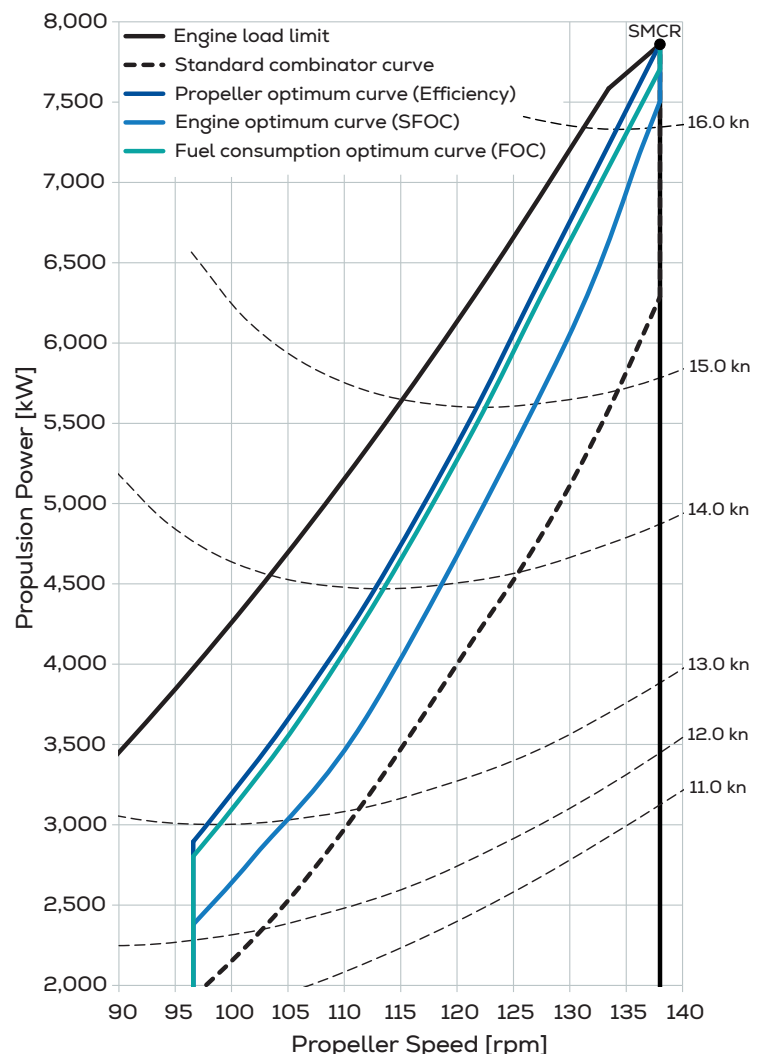

### Synchro phasing

Synchronization of rotational speed for multi-engine/multi-propeller installations is an optional feature from the Alphatronic 3000 PCS. Propeller and engine synchronization serves mainly to improve the onboard comfort by reducing vibrations and audible pulsations from rotational masses and equipment running out of sync. With difference in rotational speed of two propellers, varying noise and vibrations may occur – also known as vibration beating – causing fatigue loading on vessel structures and crew/passenger discomfort.

Our synchro phasing solution offers accurate control of the propeller speed and phase angle between the propellers – radically reducing propeller induced vibrations and noise. The solution covers two- and four-stroke engine powered twin-screw propulsion plants – for both variable speed and constant speed mode.

The solution includes a tacho-system with dual sensors, control algorithm and function control in the Alphatronic 3000 PCS, vibration measurements of max. 12 points (before and after) with post-processing of data and reporting, commissioning of system with phase angle optimization. The synchro phasing can be pre-ordered – or retrofitted if operation shows a need for vibration reduction.

Fig. 27a: Engine SFOC map  
– two-stroke example

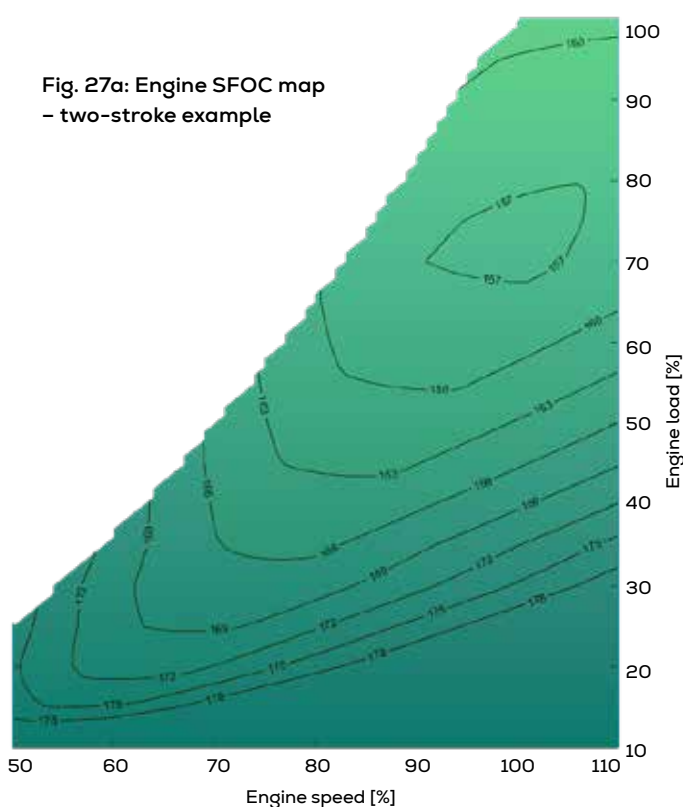

### Pitch setting fine adjustment

A softkey function for fine adjustment of the pitch setting is available – for example customized for vessel's operating conditions. In combinator mode, the fine adjustment controls both propeller speed and pitch setting, with possible steps of +/- 1% and +/- 10% respectively.

### Control of two-step gearboxes

Various clutch configurations are controlled by the PCS – either to reduce or to step up the speed from the engine and transmit the power to the propeller and/or to a PTO.

### Control of hybrid packages

The Alphatronic 3000 system can also control hybrid propulsion package concepts like HyProp ECO. A system solution that combines a diesel engine with a frequency-converter-driven shaft-alternator/motor and features multiple operational modes. HyProp ECO is also open for shore connection and the integration and usage of energy storage devices/batteries.

### Panama instruments

To fulfil the Panama Canal requirement for indication of propeller pitch and shaft speed on the bridge, a number of displays are available for bulkhead mounting.

The instruments communicate with the PCP on the location. The dimmer function in the display on the location is used for illumination control in the connected instruments.

The standard indoor version comprises indication of pitch and shaft speed orders and feedback. The instruments are readable on a distance of 10 m and a typical setup with three sets of indicators is sufficient for fulfilling of the Panama requirements.

The outdoor version for CPP comprises indicators for propeller pitch and shaft speed. For FPP, shaft speed and the direction of propeller rotation is indicated.

### Chief engineers cabin

A propeller instrument panel is available in two versions for the chief engineer's cabin.

The standard indoor Panama instrument can be delivered as a flush mounted version or in a box intended for wall mounting.

### Power supply

Duplicated power supply with battery backup for at least 30 minutes of blackout operation is a standard required yard supply.

On request, a power supply with duplicated power input, battery backup and fuses for power distribution to the propulsion control systems can be incorporated in the delivery.

### Manoeuvre printer

Standard manoeuvre data is handed over to the voyage data recorder system via an NMEA serial line according to IEC/EN 61996 and IEC/EN 61162-1. An optional matrix printer is available for logging of manoeuvre data.

A manoeuvre printer will only be added as additional equipment on specific customer request.

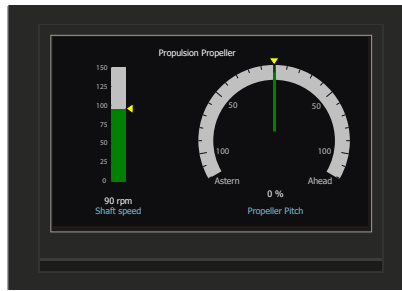

Fig. 28: Panama instrument – Propeller Indicator Panel – PIP standard indoor version

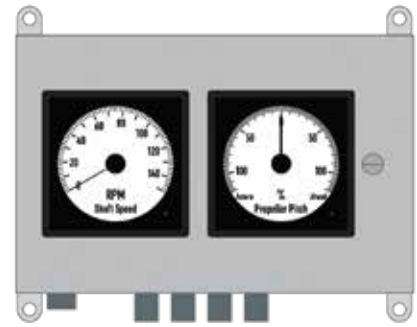

Fig.29: Panama instrument for open bridge wings

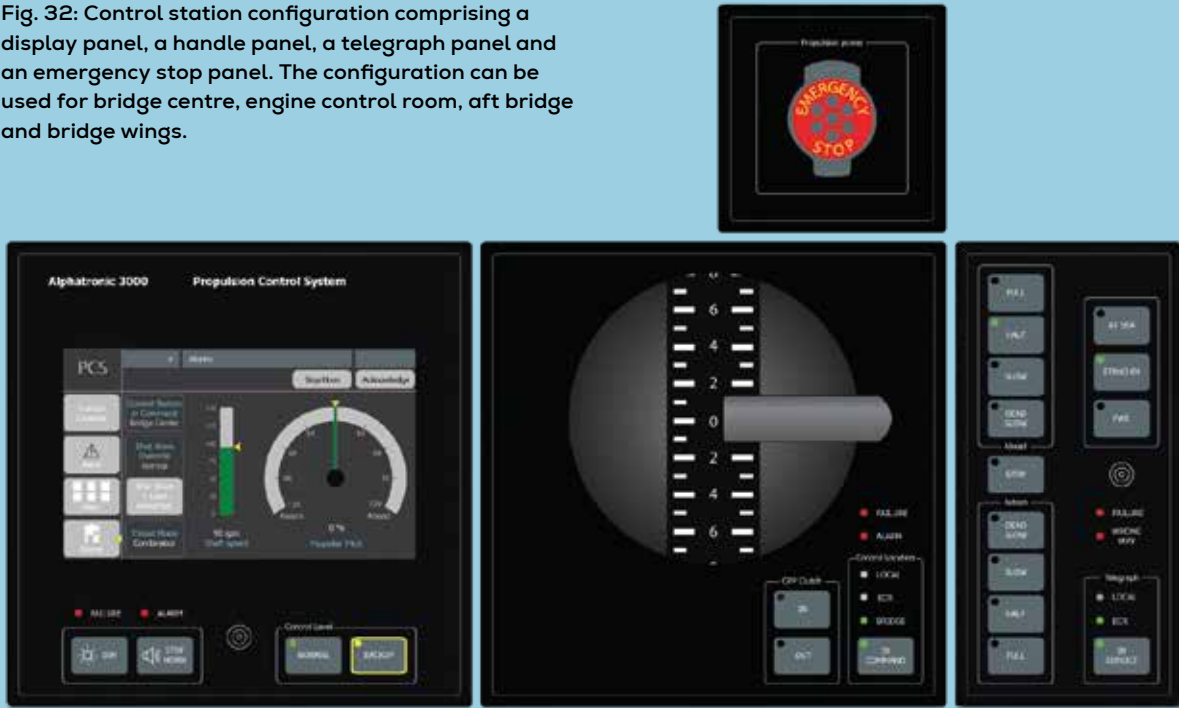

Fig.30: Power supply unit



Fig.31: Manoeuvre printer

Fig. 32: Control station configuration comprising a display panel, a handle panel, a telegraph panel and an emergency stop panel. The configuration can be used for bridge centre, engine control room, aft bridge and bridge wings.



**Examples of control station configurations**

**Standard configuration for single propeller plant**

The standard configuration shown in Fig. 32 can be used for bridge center and engine control room console positions for a single-propeller plant.

The configuration comprises a propeller instrument panel, a handle panel and an emergency stop panel. The telegraph order panel is only mandatory for CP propeller plants.

The configuration can also be used on all bridge slave control stations (bridge wings or aft bridges, e.g. for offshore vessels, workboats and fishing vessels).

On the bridge slave stations, the emergency stop panel can be excluded, and further the propeller instrument panel can be excluded if propeller pitch and shaft speed from the control station is readable on another instrument in the bridge area.

On outdoor control stations (with protection requirements IP56) the standard instrument must be replaced by a water proof version. The handle and the emergency stop panels are with an additional gasket suitable or installation on open bridge wings.



Fig. 33: Bridge wing configuration – indoor

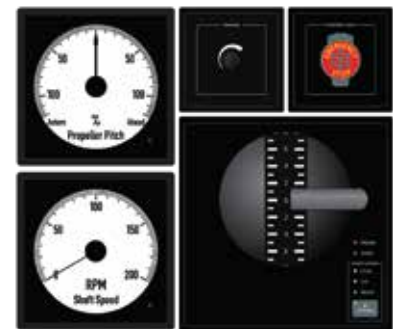

Fig. 34: Bridge wing configuration – outdoor

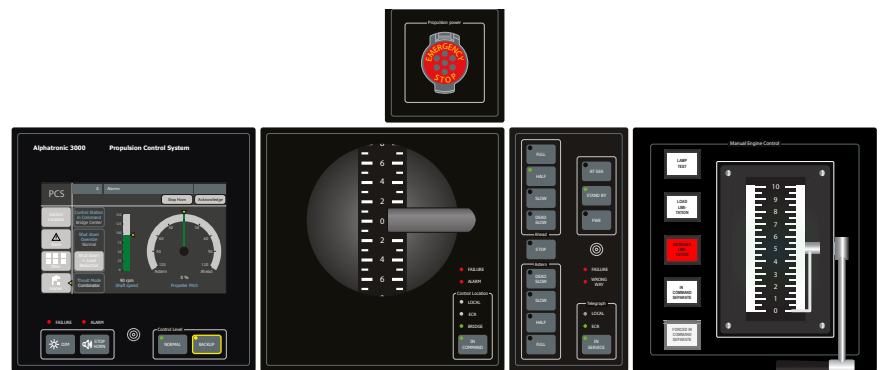

Fig. 35: ECR control station with optional EHP panel for a two stroke engine with CP propeller

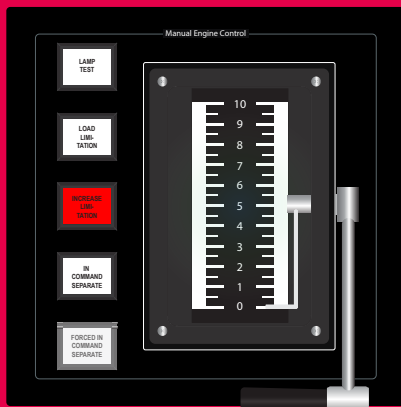

Fig. 36: Two-stroke Engine Handle Panel – EHP



Fig 37: Bridge centre and ECR control station layout for a twin-propeller plant

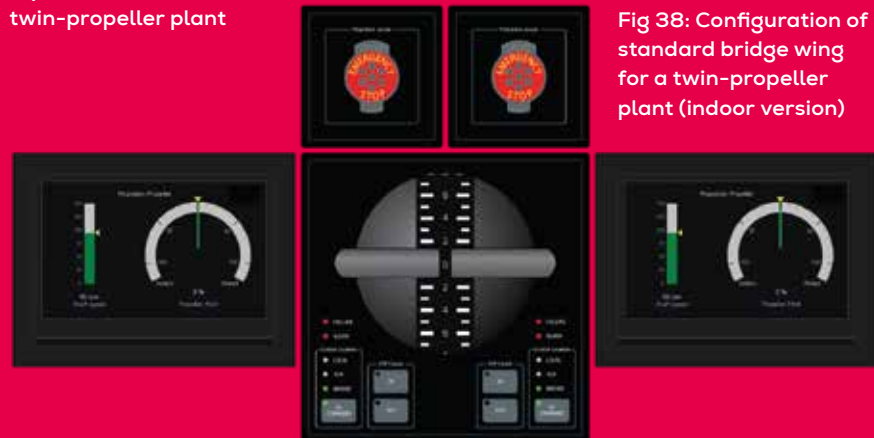

Fig 38: Configuration of standard bridge wing for a twin-propeller plant (indoor version)

### Control stations for engine control room

For four-stroke medium speed and high speed engines, the standard control station configuration for single-propeller plant can be used in the engine control room (ECR) as well. The configuration comprises a display panel, a handle panel, a telegraph panel and an emergency stop panel.

For two-stroke low speed engines, an additional optional engine handle panel (EHP) can be added for independent start, stop and speed setting of the engine from the ECR.

The EHP comprises basic control functions, such as a push button for command take-over, a lever for engine start, stop and speed setting function.

### Standard control station configuration for twin-propeller plant

This configuration can be used in bridge center, ECR, aft bridge, and bridge wings. The configuration comprises two display panels, a double handle panel, two telegraph panels and two emergency stop panels.

### Standard bridge wing control station configuration for twin-propeller plant

The configuration can be used on all bridge slave control stations (bridge wings or aft bridge). The setup comprises a propeller instrument panel, a handle panel and an emergency stop panel.

On the bridge slave stations the emergency stop panel can be excluded and the propeller instrument panel can be excluded if propeller pitch and shaft speed from the control station is readable on another instrument in the bridge area.

Fig. 39: Twin-in single-out configuration for bridge and ECR (shown with emergency clutch panel)

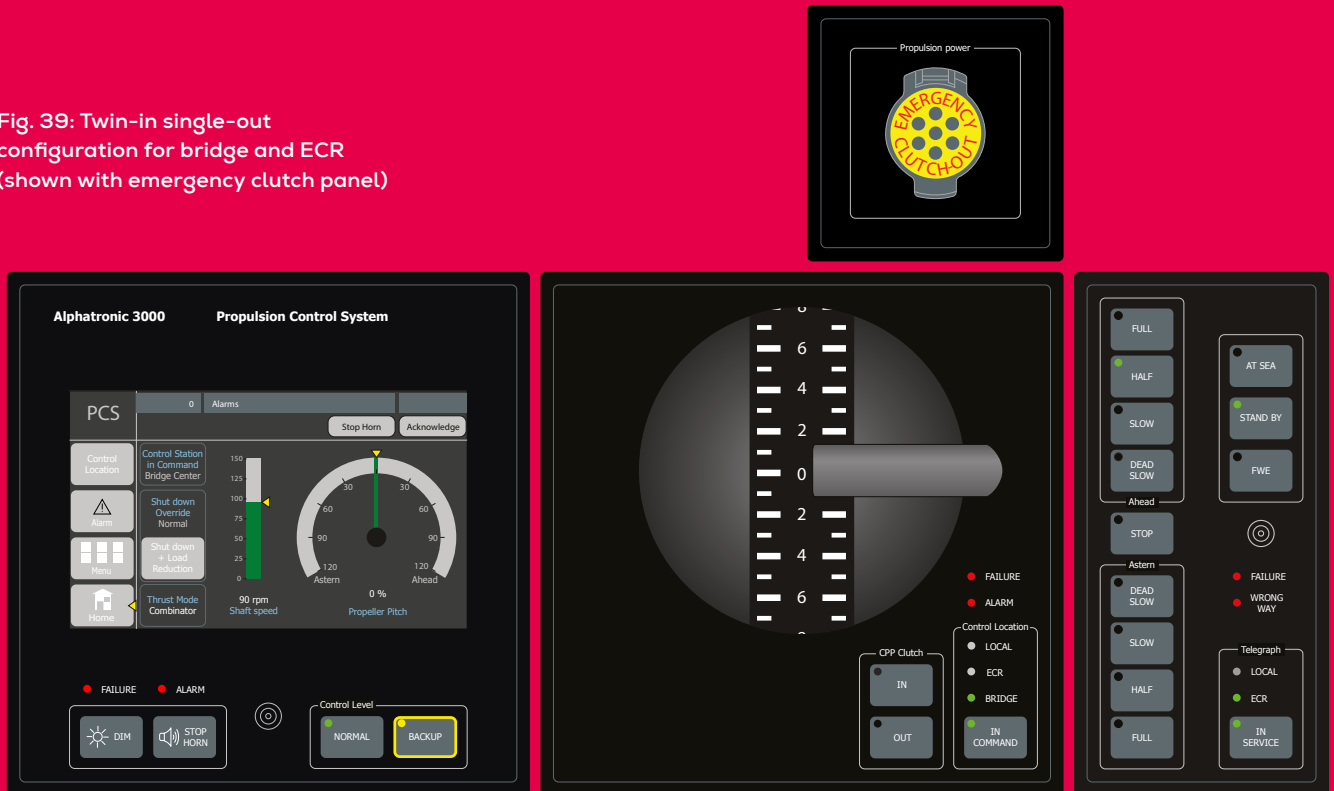

On outdoor control stations with protection requirements IP56, the standard instrument must be replaced by a water proof version as shown in Fig. 34 for the single-propeller outdoor control station.

The manoeuvring handle panels and the emergency stop panels can be installed on open bridge wings if an additional gasket is installed.

### Standard control station configuration for single-propeller as twin-in single-out plant

This configuration comprises one common PCP for the shaft line, a handle panel, a telegraph panel and an emergency stop panel. The configuration can be used in bridge center, aft bridge and bridge wings and engine control room.

The emergency stop panel might be replaced by an emergency clutch-out panel. Emergency stop or clutch-out will stop or clutch out related engines. The PCP comprises mimics for start and stop of all engines related to the shaft line.

## Propulsion setup and thrust control

The Alpatronic 3000 system is able to meet a wide range of requirements for various propulsion setups. General propulsion in constant speed mode, combinator mode or separate control of propeller pitch and engine speed is available as standard. Operation with shaft generator (SG) is possible in constant speed and variable speed mode.

Complex propulsion setups with gear boxes comprising several clutches are available as combinations of diesel mechanical and diesel electric setups with power boost, power take home, two-step propulsion power transmission as well as SG load dependent combinator curves related to variable frequency mode.

### Propulsion setup

From the propulsion control panels menus are available for:

- Automatic or manual preparation and end-operation of the relevant auxiliary systems needed for the propulsion machinery.
- Start and stop of the main engine and for applications with power take home menus for start and stop of the electro motor.
- Control of gear clutch(es) for setup of available combinations of power transmissions.

### Transfer of responsibility

Responsibility changeover between the incorporated independent control levels 'Local control', 'Non-follow-up control', 'Backup control' and 'Normal control' level is handled by the system.

In 'Normal control' level changeover – between the control locations engine room, engine control room and bridge area – require request and accept from the operators involved in the transfer of responsibility.

### Electric shaft lever synchronization

Changeover between control stations on the bridge is done as an 'in-command request' from the control handle where the navigator on the bridge wants to control the propulsion.

All manoeuvring handles are automatically aligned, and bumpless takeover of responsibility can be effected without the need of manual alignment of the levers.

Changeover to external control systems such as a joystick control system, dynamic control system or dredge control system is possible as an 'in-command request' from the external system. Further changeover between an incorporated speed pilot and an external navigation system with route planning system is also possible.

### Thrust control modes

As standard, propulsion in constant speed, combinator and separate control modes is available. Operation in constant speed mode is available with propulsion power boost via a PTO/PTI shaft generator/motor powered from GenSets, winch motors or other electrical sources.

Combinator mode for normal operation without shaft generator in service – or with shaft generator in service at variable speed mode is also available.

### Combinator curves

A number of combinator curves can be implemented for optimization of propulsion in different load conditions for the shaft generator and the propeller.

For reduction gears with two different gear steps and reduction ratios between main engine and propeller – separate combinator modes can be added, for example for part load and low load propulsion optimization.

For fishing vessels, for example, different combinator curves can be defined for optimal free sailing mode and optimal trawling mode respectively.

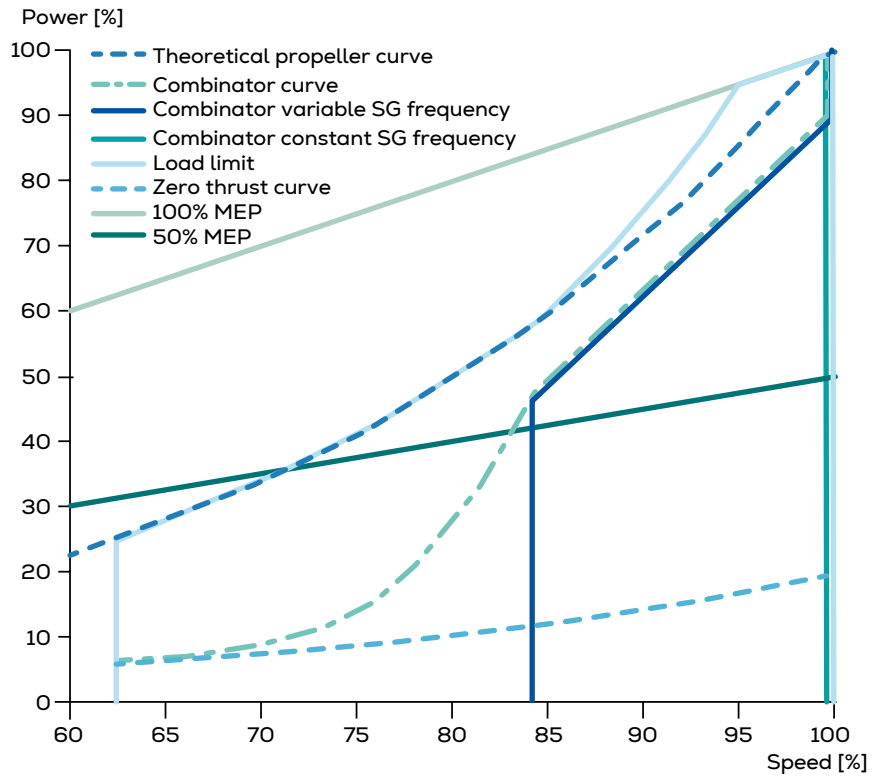

Fig. 40: Simple load diagram

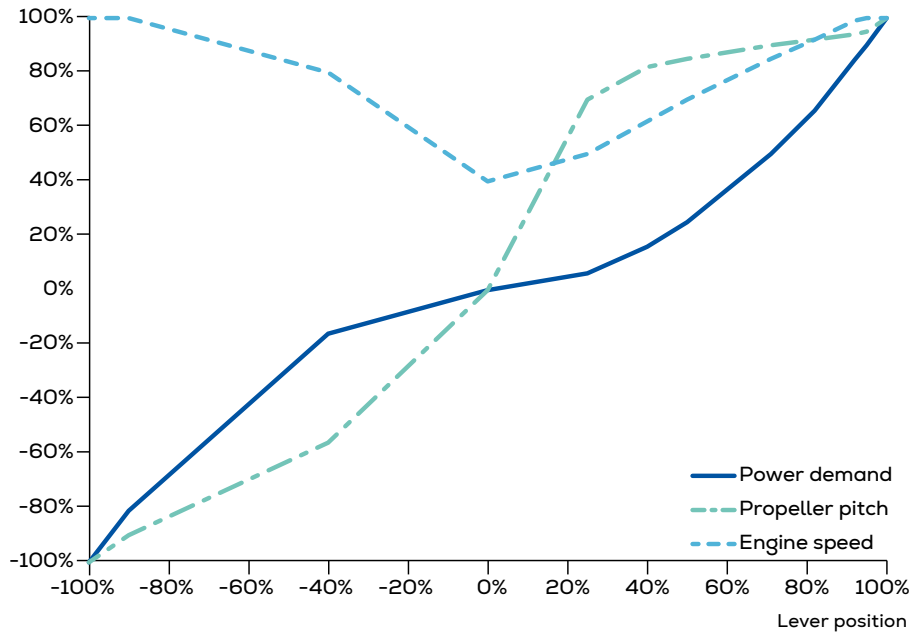

Fig. 41: Combinator curve two-stroke standard example: Power demand, propeller pitch and shaft speed related to lever position

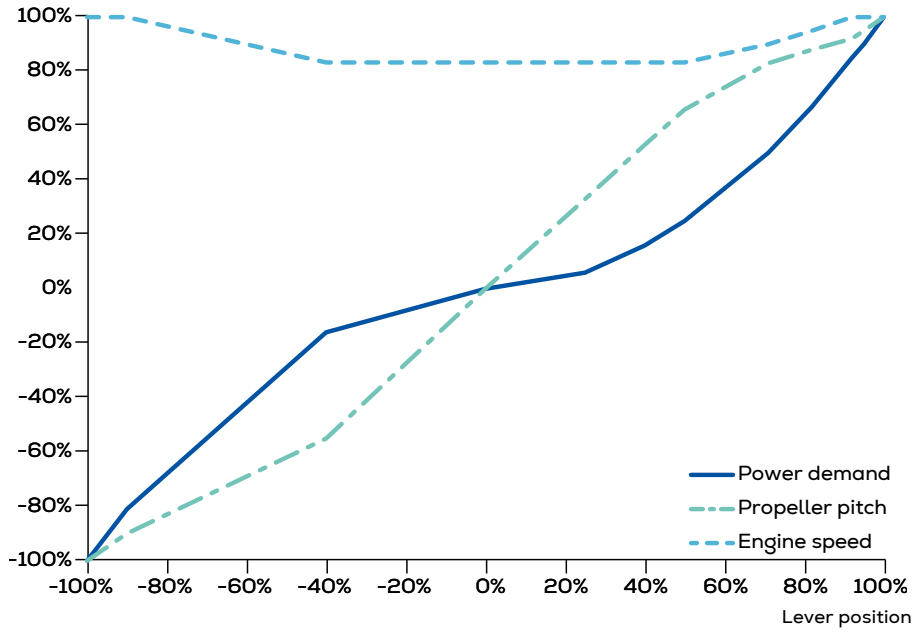

Fig. 42: Combinator curve standard variable SG frequency: Power demand, propeller pitch and shaft speed related to lever position

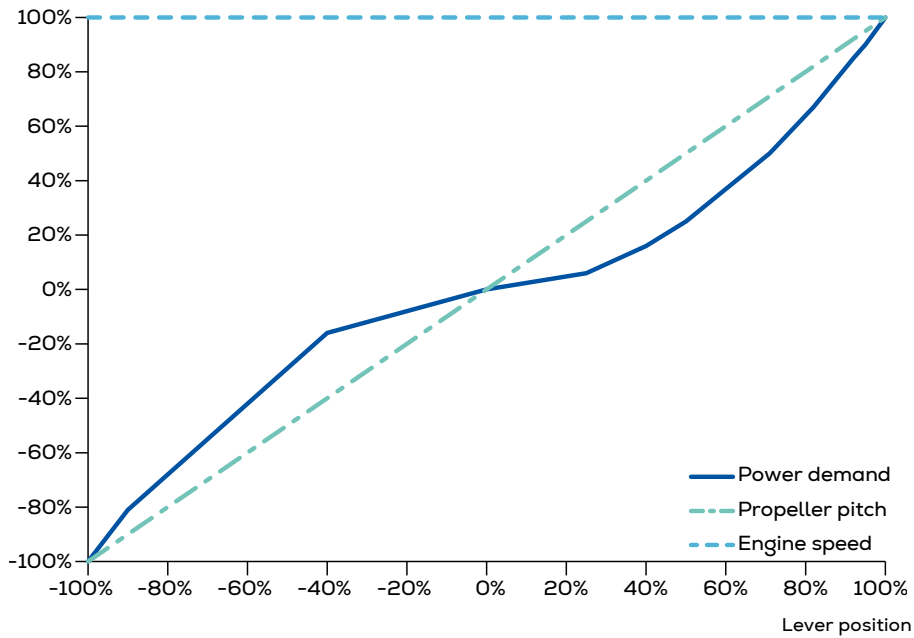
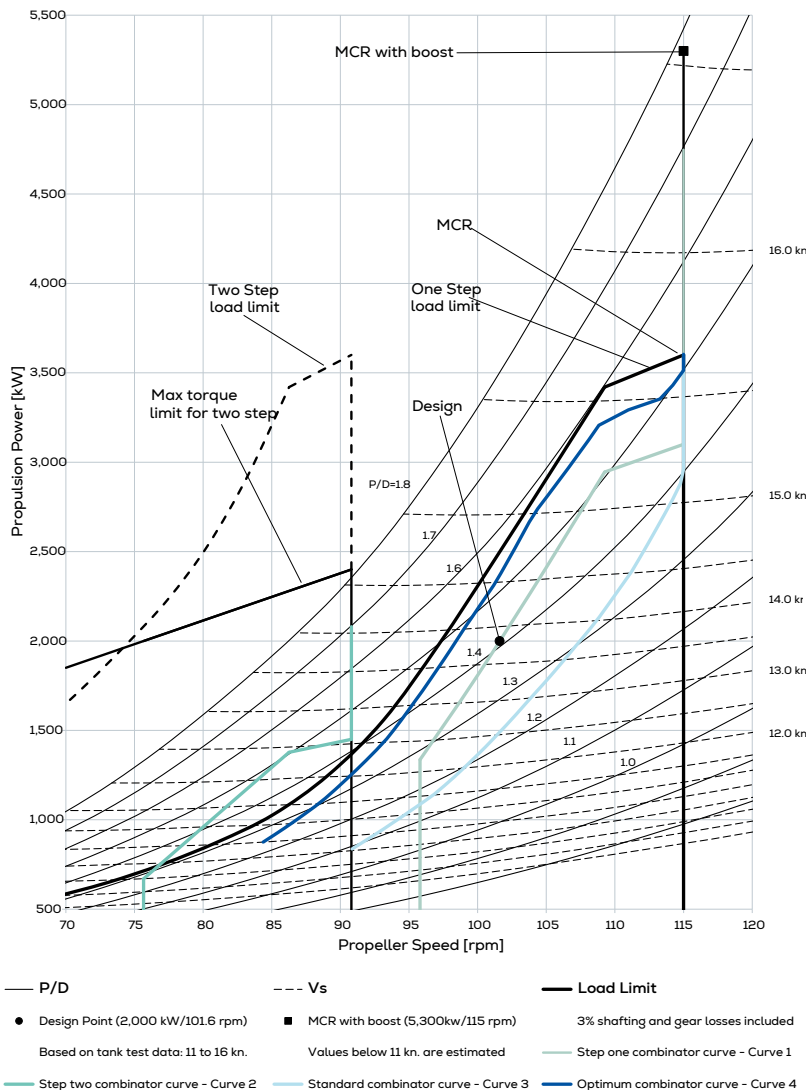

Fig. 43: Combinator curve for constant speed mode: Power demand, propeller pitch and shaft speed related to lever position



**Fig. 43a: 6L32/44CR rated 3,600 kW with a power boost of 1,700 kW:**  
 Example of combinator curves for a fishing vessel with normal operation of SG in constant or variable frequency modes and diesel electric propulsion with power boost or power take home mode.

Further, the gear step 2 can be used for reduced propulsion power at low propeller speed and, at the same time with high power available for the SG. Values are based on vessel's design condition, no sea margin and a draft aft of 8.05 m.

### Protection of propulsion machinery

The system comprises interlocks for unintended start or engagement of the machinery. No actions from the user must lead to machinery damage or loss of manoeuvrability.

For safe manoeuvrability an interface to the engine safety system enable the operator to override engine shutdown and load reduction. A pre-warning alarm informs the operator before propulsion power is lost or automatically reduced by the engine safety system.

The automatic load control function protects the machinery against overload during acceleration and in free sailing mode in rough weather condition. In power take-home mode, the system will protect the electro motor against overload.

For twin-in single-out applications the load sharing between the engines typically is done in the engine governor system, but with speed droop in the governors load sharing can be incorporated in the propulsion control system even including compensation of the speed droop in the governor.

### Barred speed range

The Alphatronic 3000 engine speed control makes sure that operation in possible barred speed ranges are avoided – and that critical speed ranges are 'passed quickly' during running-up and running-down. For two-stroke plants this protection of engine and shaft system is important and a barred speed range will be clearly indicated on the engine speed displays.

## Overall system architecture

### Power distribution

#### Power supply

Being an essential consumer, the power to the propulsion control system is divided into two different distribution lines. The main supply for the two power supplies must be from independent sections of the main power system onboard the vessel.

In the installation documentation, the two supplies are described as Power A and Power B.

Power A must be supplied by an AC/DC converter to ensure galvanic isolation, and Power B must be a 24 V DC no-break power supply with at least 30 minutes battery back-up.

### The power from the two power supplies are distributed in three groups each

|                                   |                                   |
|-----------------------------------|-----------------------------------|
| Propulsion control system:        | nominal load 80W, peak load 150W  |
| Bridge propulsion control panels: | nominal load 100W, peak load 200W |
| Local propulsion control system:  | nominal load 150W, peak load 200W |

Standard Reference: 2171064-2 Power distribution

Standard Reference: 2171052-2 General requirements for installation

Fig.44: Alphatronic 3000 power distribution architecture

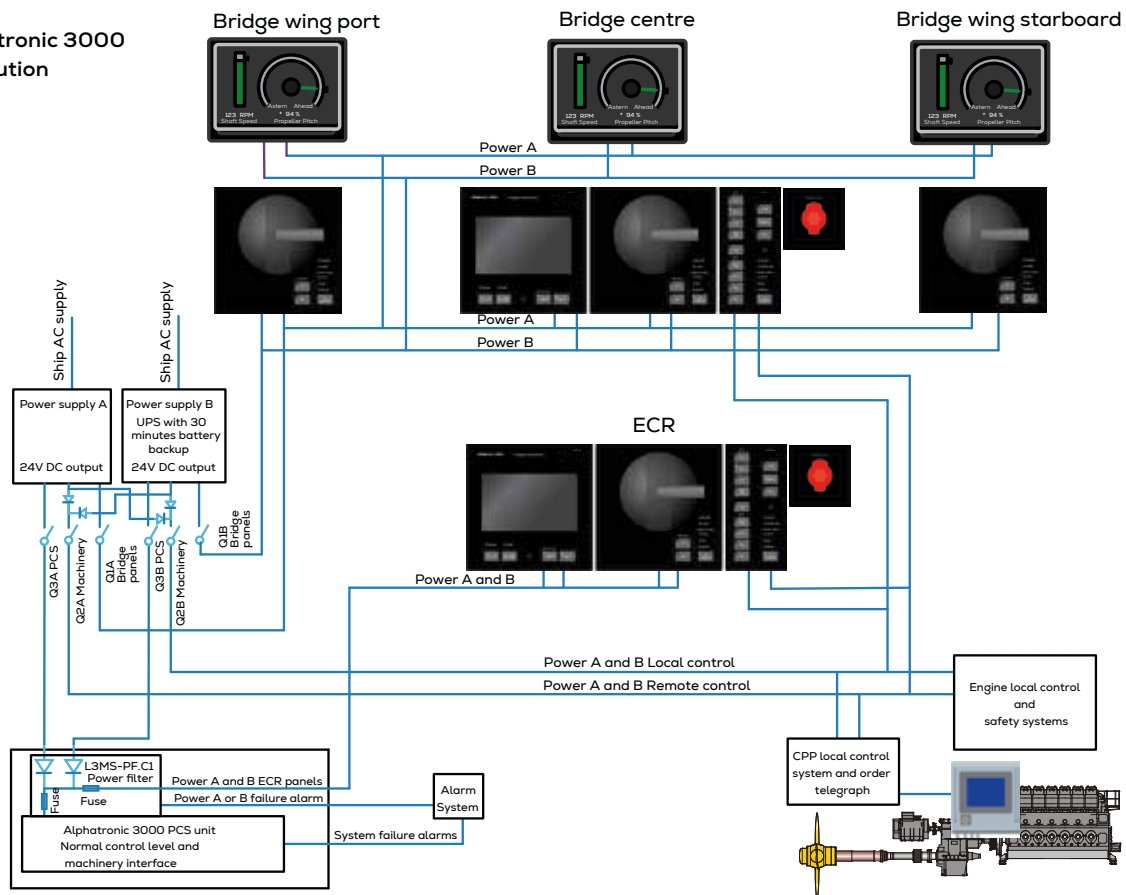

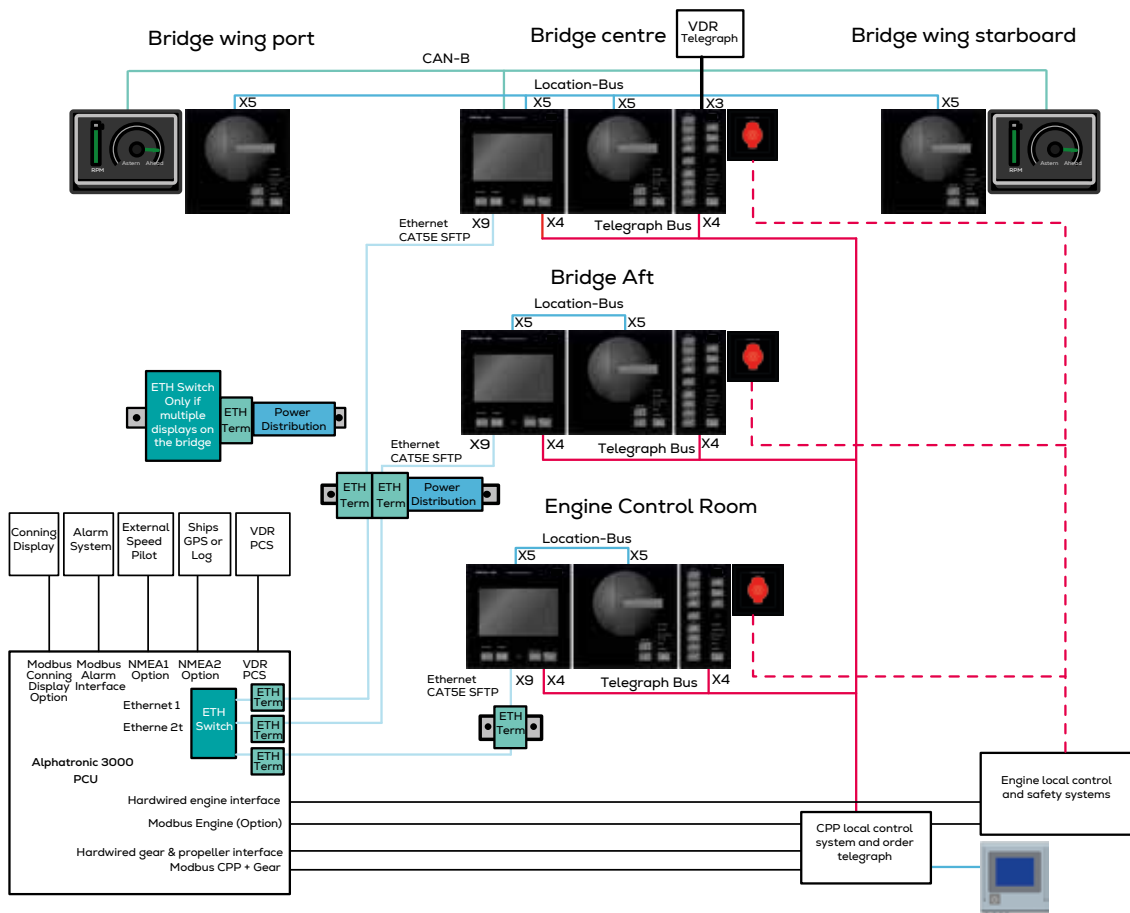

Fig. 45: Alphasatronic 3000 networks architecture

### Networks architecture

To ensure a high level of independency, the communication between system panels are done with a number of independent networks.

The Alphasatronic 3000 propulsion control unit is communicating with the display panels via the internal system ethernet. Each propulsion control panel communicates with the related levers via a location bus. Additional propeller instrument panels are connected to the display panels via a CAN-bus.

The telegraph panels are connected via the independent telegraph bus to the local propulsion control system for communication of telegraph orders from the bridge to the machinery space.

The propulsion control panels are as well using the telegraph bus for communication of backup control orders and feedback.

Depending on the possibilities for the propulsion machinery to be controlled hardwired and/or serially, connections are available for communication of

orders and feedback between the propulsion control system and the propulsion machinery.

### Cabling

If the cable length between the machinery space and navigation bridge is more than 100 m, an optical fiber breakout cable must be used for the Ethernet connection to the bridge.

## Interface to propulsion machinery

### Engine interface: Engine start/stop, speed control and load control

- Large-bore four-stroke medium speed engines: The interface comprises hardwired interface for engine safety system, control transfer, engine speed and load control. Optionally remote start and stop of engine can be included.
- Small-bore four-stroke medium speed engines: The interface comprises serial interface for engine safety functions, control transfer, remote start and stop, speed setting and load control. Furthermore, the local operator panel for the propeller is incorporated in the engine local operator panel, and the separate local propeller panel is not needed for these applications.

- High-speed engines: The interface comprises hardwired interface for engine safety system, control transfer, and engine speed and load control. Optionally remote start and stop of engine can be included.
- Low-speed two-stroke engine types MC-C and ME-B: The interface comprises hardwired interface for engine safety system, control transfer, engine speed, and load control. Remote start and stop of engine is included in the normal control level and, additionally from the ECR with an optional independent handle for manual start, stop, and speed setting of the engine.
- Low-speed two-stroke engine types ME-C and ME-GI: The interface comprises hardwired interface for engine safety system and duplicated serial interface for control transfer, and

engine speed and load control. Remote start and stop of engine is included in the normal control level and, additionally from the ECR with an optional independent handle for manual start, stop, and speed setting of the engine.

### Engine interface: Engine safety shutdown and load reduction

The table in Fig. 46 shows the available interface between the engine safety system and the Alpatronic propulsion control system.

### Gear interface: Power transmission and clutch control

- Gear with propeller clutch. Hardwired interface to the LPCU for control of the clutch will make it possible to control the clutch from the bridge and from the local operating panel for the propeller.
- Gear with propeller clutch and primary PTO to SG.

| PCS I/O Type | PCS Symbol | Safety system Symbol      | Description  |
|--------------|------------|---------------------------|--|
| DO           |            |                           | ZS4735 Shutdown override request<br>CC = Shutdown override request                 |
| DI           |            |                           | ZSI4735 Shutdown override active<br>CC = Shutdown override active                  |
| DO           |            | Available if needed       | ZS4736 Shut down reset<br>CC = Shutdown reset pulse                                |
| DI           |            | Line supervision expected | ZS4710 Emergency stop - request<br>CC = Emergency stop (two signals are available) |
| DI           |            |                           | ZSI4710 Emergency stop - active<br>CC = Emergency stopped                          |
| DI           |            |                           | ZSI4738 Shutdown pre-warning<br>CC = Shutdown pre-warning                          |
| DI           |            |                           | ZSI4737 Shutdown zero pitch request<br>CC = Shutdown active                        |
| DI           |            |                           | ZS4748 Load reduction pre-warning<br>CC = Pre-warning                              |
| DI           |            |                           | ZS4747 Automatic load reduction<br>CC = Request load reduction                     |

For two-stroke engines the safety system often only comprise of shutdown sensors. Slowdown or load reduction sensors are then typical handled in the ship's alarm system as a second limit on the parameter covered by a general warning of a critical measurement. For these applications the slowdown or load reduction signals will come from the ships alarm system and not from the engine safety system

Fig. 46: Available interface between the engine safety system and the Alpatronic propulsion control system – for engine safety shutdown and load reduction

Hardwired interface to the LPCU for control of the clutch will make it possible to control the clutch from the bridge and form the local operating panel for the propeller.

- Gear with propeller clutch, PTO clutch and PTI clutch. Hardwired interface to the LPCU for control of the clutches will make it possible to control the clutches from the bridge and form the local operating panel for the propeller.
- Gear with two engine clutches intended for twin-in single-out applications. Hardwired interface to the PCU for control of the clutches will make it possible to control the clutches for speed synchronization during engagement and unload of engines before disengagement.

### **Propeller interface: Propeller pitch and shaft brake control**

- Local propulsion control system (LPCS): Two serial interfaces to the LPCS enable independent functionality in normal and backup control level. The interfaces comprise functionality for CPP servo oil pump control, pitch control remote clutch control and shaft brake control. (For further details see last chapter in this paper).

### **Interfaces to external control and monitoring systems**

#### **Interface to ship alarm system**

Alarm and monitoring parameters provided by the Alphasonic 3000 propulsion control system for monitoring and announcement in the ship's alarm system are specified in a plant specific summary of alarms. The data

transmitted on the modbus to the ship's alarm system comprises a combination of alarm parameters requiring the attention from an engineer, propulsion status and monitoring parameters available for general information in the ships alarm and control system.

Standard reference drawing: 2173577-0 Summary of Alarms.

(Standard reference drawings are available and can be acquired by contacting Everllence)

#### **Interface to voyage data recorder (VDR)**

The status in the normal control system is transmitted to the voyage data recorder system via a NMEA serial line according to IEC/EN 61996 and IEC/ EN 61162-1.

The status in the telegraph system is independent of the normal control status and is also transmitted to the voyage data recorder system via an NMEA serial line according to IEC/EN 61996 and IEC/EN 61162-1.

Standard reference: 2171083-3 VDR interface for normal control level. Standard reference: 2171084-5 VDR interface for telegraph orders and backup control level.

#### **Interface to GPS for Alphasonic 3000 speed pilot and master clock**

An interface from the GPS is needed if the optional Alphasonic 3000 speed pilot is included in the supply. The interface is made according to the NMEA 0183 standard for interfacing marine electric devices. A GPRMC sentence

comprising 'speed over ground' information is expected to be received from the GPS. The interface for the GPS can as well comprise the master clock functionality with control of UTC and local time via a ZDA sentence from the GPS to Alphasonic 3000.

Standard reference: 2172660-2 Interface for Speed Pilot

Standard reference: 2188788-6 Interface to Master Clock

Further, the Alphasonic 3000 can include interface to the ship's navigation system if the ship speed and course is intended to be automatically controlled by a high level route planning system.

#### **Interface to DP and joystick control system**

It is possible to transfer the control of the main propeller pitch to an external control system such as a dynamic positioning system or a joystick control system. Control can be transferred to an external system when the manoeuvring responsibility is on the bridge, the engine is running and the propeller is engaged. During joystick control, the engine is still fully protected against overload.

With independent interfaces to a dynamic positioning system and a joystick control system the Alphasonic 3000 system fulfils the IMO requirements for dynamic position class 2 (DP2).

Standard reference: 2176193-8 Interface to DP system and/or joystick control system

**Interfaces to switch board and power management system (PMS)**

**Interface to power take off from shaft generator (PTO)**

The most common type of power take off (PTO) is a shaft generator running at a fixed frequency. However, today a large number of shaft generator installations are designed for operation in variable speed mode.

Alpatronic 3000 is able to fulfil requirements for both constant and variable speed mode.

Standard reference:  
2171087-0 PTO interface for SG for fixed frequency

Standard reference:  
2178800-7 PTO interface for SG for variable frequency







| PCS I/O Type | PCS Symbol  | JS/DP Symbol  | Description                                       |
|--------------|---|---|---|
| AI           |   |    | Thrust command<br>4-12-20mA= 100%AS - 0 - 100%AH  |
| AO           |    |   | Thrust feedback<br>4-12-20mA= 100%AS - 0 - 100%AH |
| DO           |  |   | Overload, pitch reduced<br>CC = Reduced           |
| DO           |  |   | Propeller ready for JS/DP<br>CC = Ready           |
| DO           |   |  | Request command<br>CC = Request                   |
| DO           |  |   | JS/DP in command<br>CC = In control               |

Fig. 47: Interface to DP system and/or joystick control system







| PCS I/O Type | PCS Symbol  | PMS Symbol  | Description   |
|--------------|---|---|---|
| DO           |  |   | EC4811 PTO ready<br>CC = Ready                                    |
| DO           |  |   | EC4813 PTO out of service demand<br>CC = SG out of service demand |
| DI           |   |  | ECS4810 breaker closed<br>CC = Breaker closed                     |
| DI           |   |  | ECS4814 PTO constant speed<br>CC = Closed for constant speed)     |
| DI           |   |  | ECS4815 PTO variable speed<br>CC = Closed for variable speed)     |
| DI           |   |  | ECS4812A increase RPM<br>CC = Increase speed                      |
| DI           |   |  | ECS4812B decrease RPM<br>CC = Reduce speed                        |

Fig. 48: Interface to PTO from shaft generator

### Interface to power take home (PTH)

Some vessels, e.g. chemical tankers, fishing vessels and offshore vessels need the option of switching to alternative propulsion power if the main engine is not available.

Such alternative propulsion can be established by using the shaft alternator as a shaft motor. A number of prerequisites must be considered.

It must be possible to disengage the main engine before the shaft motor can be engaged, and there must be a way of bringing the shaft motor from standstill to nominal speed.

As a rule of thumb, electrical power corresponding to at least 25 - 30 % of the main engine power must be available.

Preferably, the combined PTO/PTI could be connected via a two-speed gear. This will reduce the required PTI power and the associated equipment for starting the PTI from standstill.

Standard reference:  
2174843-5 Interface to PMS  
for power take home mode

| PCS I/O Type | PCS Symbol | PMS Symbol | Description  |
|--------------|------------|------------|--|
| DO           |            |            | PTI Start command<br>CC = Start (pulse)                      |
| DO           |            |            | PTI running<br>CC = Running                                  |
| DO           |            |            | PTI Stop command<br>CC = Stop (pulse)                        |
| AI           |            |            | Electric motor load<br>4-20mA = 0-110%                       |
| AI           |            |            | DG relative load<br>4-20mA = 0-110%                          |
| DO           |            |            | PTH clutch engaged<br>CC = Engaged                           |
| DI           |            |            | PTH ready for engagement<br>CC = Ready                       |
| DI           |            |            | PTH shutdown auto clutch out request<br>CC = Auto clutch out |
| DI           |            |            | PTH start blocking, PMS not ready<br>CC = PTH start blocking |
| DO           |            |            | Emergency stop   |

Fig. 49: Interface to PMS for PTH mode

**Interface for power boost**

This feature may be relevant for short term boosting of the propulsion power. It is necessary that the gear and the propeller are designed for the total power of diesel engine and shaft motor. It is necessary that the amount of power supplied by the shaft motor is controlled by the ship's power management system.

Power boost can be arranged as a simple PTI controlled by the power management system without interface between PCS and PMS, but typically an interface including requests for engagement/ disengagement of boost power is commanded by the operator on the bridge, and boost power from the diesel generators is only requested if the main engine is high-loaded.

Standard reference:  
2171085-7 Interface for power boost with priority of DG power

Standard reference:  
2178799-0 Interface for power boost with priority of ME load

**Interface to fire fighting pump**

Interface to a fire fighting pump depends on the actual application, but typical request is information of high engine load, full engine load and speed control related to engagement of the pump.

**Interface to a dredge control and monitoring system**

Interface to a dredge control system is necessary if the dredge pump is mechanically connected to the propulsion shaft line. A dredge pump system interface needs to be customized for each vessel.

Typical control will require interface for separate speed control from the dredger control system with constant thrust on the propulsion line and overload protection with high torque limitation on the main engine.

**Interface for automatic propulsion power setup (prepare/end operation)**

Basically, the Alphasatronic 3000 system comprises all necessary control and safety interlocks for manual setup of the intended propulsion modes defined for the vessel. Customized interface to high level control sequences for propulsion mode changeover is possible.

Propulsion control unit  
The propulsion control unit (PCU) is delivered in a cabinet intended for bulkhead mounting in the machinery space. The control unit comprise I/O modules for interfaces to the machinery and to the external systems.

| PCS I/O Type | PCS Symbol | PMS Symbol | Description  |
|--------------|------------|------------|--|
| DO           |            |            | Power boost engage<br>CC = Engage (pulse)                              |
| DO           |            |            | Power boost disengage<br>CC = Disengage (pulse)                        |
| DI           |            |            | Electric motor ready for power boost<br>CC = Ready (closed when ready) |
| AO           |            |            | DG boost power request<br>4-20mA = 0-100%                              |

Fig. 50: Interface to PMS for Power Boost

## Propulsion control unit

The propulsion control unit (PCU) is delivered in a cabinet intended for bulkhead mounting in the machinery space. The control unit comprise I/O modules for interfaces to the machinery and to the external systems.

The included digital processor unit is handling the system software related to normal control level which incorporates the following main control functions:

- Automatic load control with engine overload protection and engine running-up load program

- Automatic load reduction and slowdown control including waiting program for switchboard
- Electric shaft control of all included levers ensuring bumbles transfer of responsibility
- Engine start stop and gear clutch control
- Selection of thrust mode for CPP: combinator, constant or separate mode
- Self-monitoring and system failure alarm handling.

The PCU (main cabinet) consists of the following hardware modules as standard:

1. Ethernet switch.
2. Control module. DPU 2020 Data Processing Unit.
3. Combined I/O module. Combined I/O module equipped with analogue inputs, analogue outputs, tacho inputs, relay outputs, solid state outputs.
4. Digital module. Digital module equipped with both internally and externally powered digital inputs.
5. Row terminal. Row terminal complete, equipped with RJ45 to cable terminals for termination of communication and single terminal rows for power supply.

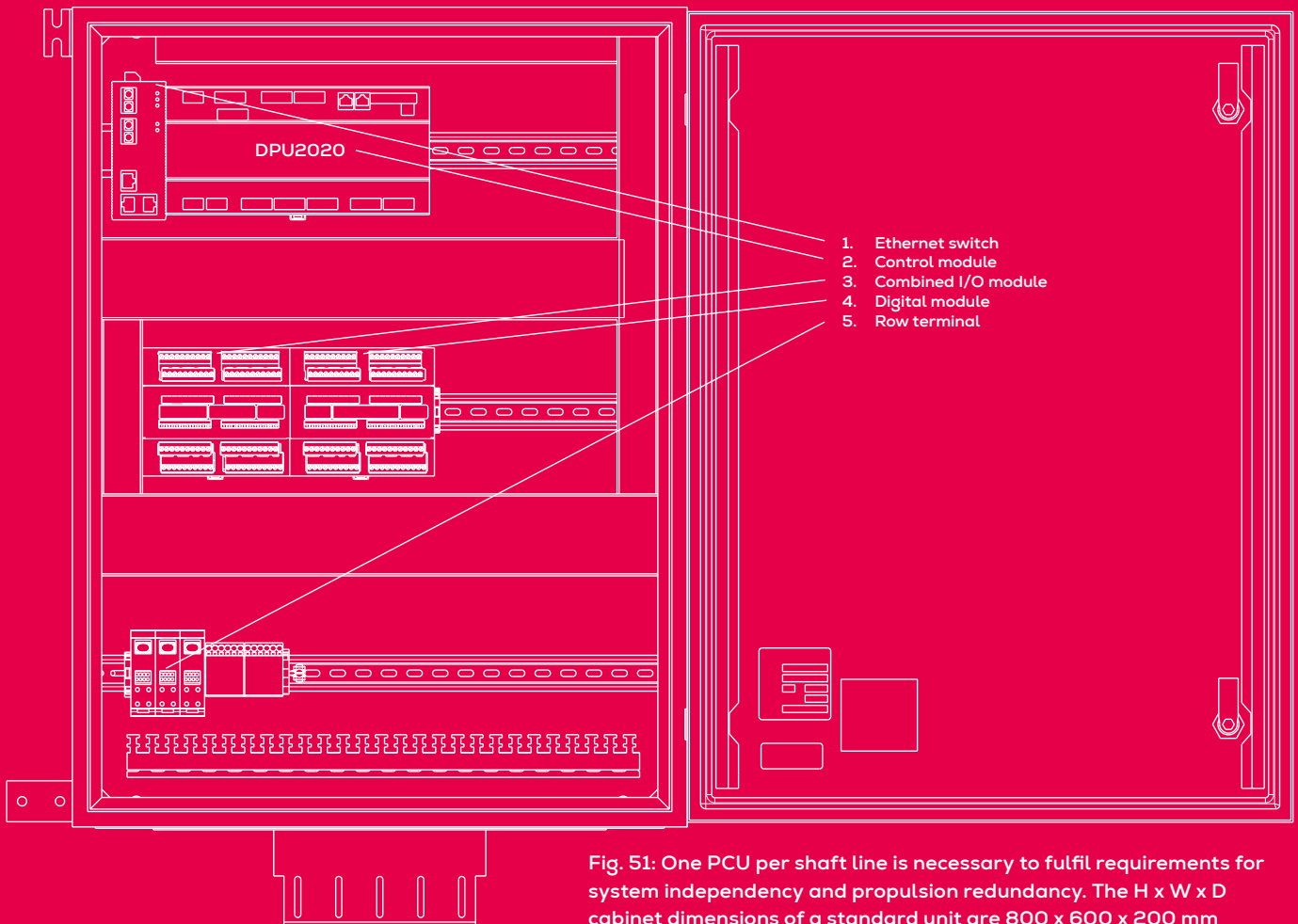

Fig. 51: One PCU per shaft line is necessary to fulfil requirements for system independency and propulsion redundancy. The H x W x D cabinet dimensions of a standard unit are 800 x 600 x 200 mm

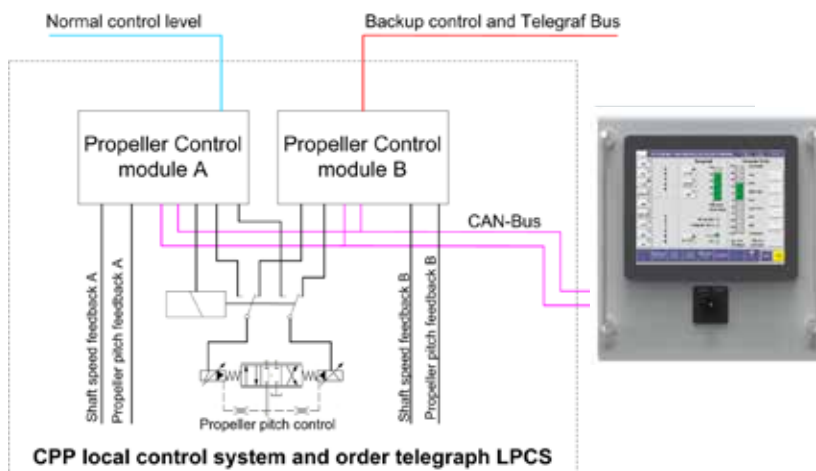

Fig. 52: Local propulsion control system (LPCS) comprising of LPCU and LOP-P

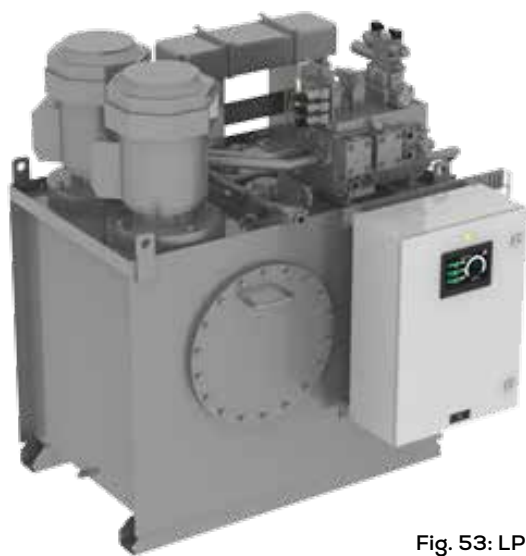

Fig. 53: LPCU box on hydraulic power unit (HPU)

## Local propulsion control system

The SaCoSone local propulsion control system (LPCS) monitors, controls and operates the CP propeller system. All sensors and operator control units are connected to the local propulsion control unit. The design of the SaCoSone LPCS is based on highly dependable and tested components and modules specially developed for use on engines.

### LPCS – system design

The system comprises:

- Local propulsion control unit (LPCU)
- Local operating panel for the propeller (LOP-P)

The LPCU contains two control modules, CMS-A and CMS-B. Both modules handle monitoring and control functions. The primary function of the CMS-A is handling of normal remote control and propeller shaft line alarms, while the primary functions of the CMS-B are handling of local pitch control and remote back-up control.

The LPCU is mounted on the propeller hydraulic power unit (HPU) and includes the local instrumentation for the propeller system with display of propeller pitch and shaft speed, as well as servo oil pressure and servo oil temperature. The pitch indicator is available for feedback at manual pitch control directly on the hydraulic control valve.

### Local operator panel for the propeller (LOP-P)

Two local operator panel solutions are available. For single-propeller propulsion packages the local propulsion control can be integrated into the engine operating panel system forming a uniform and redundant operator interface.

For plants where the local presentation of the propeller cannot be integrated with the local operator panels for the engine, the propulsion control system has its own local operator panel. To perform an integrated local propulsion control station, this panel should be placed close to the engine local control stand. Both solutions comprise exactly the same control and monitoring functions.



Fig. 54: Cabinet with local operator panel for propeller (LOP-P) – placed on four-stroke engine

### Local operator panel for the engine (LOP-E)

For two-stroke engines, the LOP-E can also be part of the Alphasonic 3000 scope of supply. The LOP-E is mounted on the engine side control stand and, can together with the LOP-P perform a complete propulsion control station with independent local control of the propulsion plant.



Fig. 55: Local operator panel for two-stroke ME-G engine – LOP-E

### Alarm and monitoring sensors from the propeller

All monitoring sensors related to the propeller shaft line are connected to the local propulsion control unit and enables local readout of all parameters on the local operator panel. Furthermore all propeller alarms are handed over to the ship's alarm system via a serial modbus line.

### Control of CPP servo oil pumps

The motor starters for the CPP servo oil pumps are control by the LPCS. Orders for preparation and ending of operation for CPP pumps can be controlled from the local operator panel. Prepare and end of operation can also be controlled as an automatic function related to start stop of the main engines or from the Alphasonic 3000 propulsion control panel in ECR.

Control mode for the CPP servo oil pumps is handled by the LPCS. Possible modes are: master operation, pre-lubricating, post-lubrication, standby operation, boost operation, wind milling operation and manual operation.

### Cable plans

Cable plans and connection lists showing each cable connection to control system terminals are supplied by Everllence – when a purchase contract has been signed and upon receipt of all necessary shipyard information.

In order to ensure the optimum function, reliability and safety of the control system, without compromise, the following installation requirements must be taken into consideration:

- Power supply cables must be at least of size 2.5 mm<sup>2</sup>.
- If the supply cable length between the bridge and the engine room is in excess of 60 meters, the voltage drop should be considered.
- The signal cables should have wires with cross sectional area of min 0.75 and max 1.5 mm<sup>2</sup>.
- All cables should be shielded and the screen must be connected to earth (terminal boxes) at both ends.
- Signal cables are not to be located alongside any other power cables conducting high voltage (i.e. large motors) or radio communication cables. The remote control signals can be disturbed by current induced into the cables from their immediate environment. Induced current may disturb or even damage the electronic control system if the cables are not installed according to our guidance.

### Commissioning

As part of the on-board acceptance procedures, a final system test of the remote control system is carried out by Everllence commissioning engineers.

A number of classification societies usually require the on-board test to be performed in the presence of a surveyor before the official sea trial.

Before the functional test, and even before the power supply voltage is switched on – the cable plan and connection lists are cross-checked with all wiring and connections made by the shipyard.

The Everllence procedure for Alphatronic remote control system test is carried out in accordance with an exhaustive check list covering a number of tasks within the following categories:

- Power up and control room responsibility
- Control panel operations and indications
- Manoeuvring responsibility and transfer
- Failure and alarm simulation
- Propeller pitch back-up control
- Shaft alternator control.

The commissioning engineers will adjust all lever positions and order signals in preparation for the fine tuning of settings for propeller pitch, fuel index, etc. performed during the sea trials.

### Instruction manual

As part of our technical documentation, an instruction manual will be forwarded. The instruction manual is tailor-made for each individual control system and includes:

- Descriptions and technical data
- Main functions and features
- Operation and maintenance guide lines
- Spare parts plates.

The standard manual is supplied in a printed version – and can as an option be forwarded in electronic file formats.

### PrimeServ Academy training

At Everllence PrimeServ ACADEMIES, we offer tailor-made training solutions, to enable you and your crew to maximize your propulsion system's efficiency. This training focuses on the needs of your target group, e.g. engineers, superintendents, operators or navigators.

Our training will be tailored specifically to your demands on the basis of the following standard course portfolio:

- Alphatronic 3000 propulsion control system – standard
- Alphatronic 3000 propulsion control system – advanced
- Propeller and Alphatronic 3000 propulsion control system – introduction
- Propeller and Alphatronic 3000 propulsion control system – advanced operation.

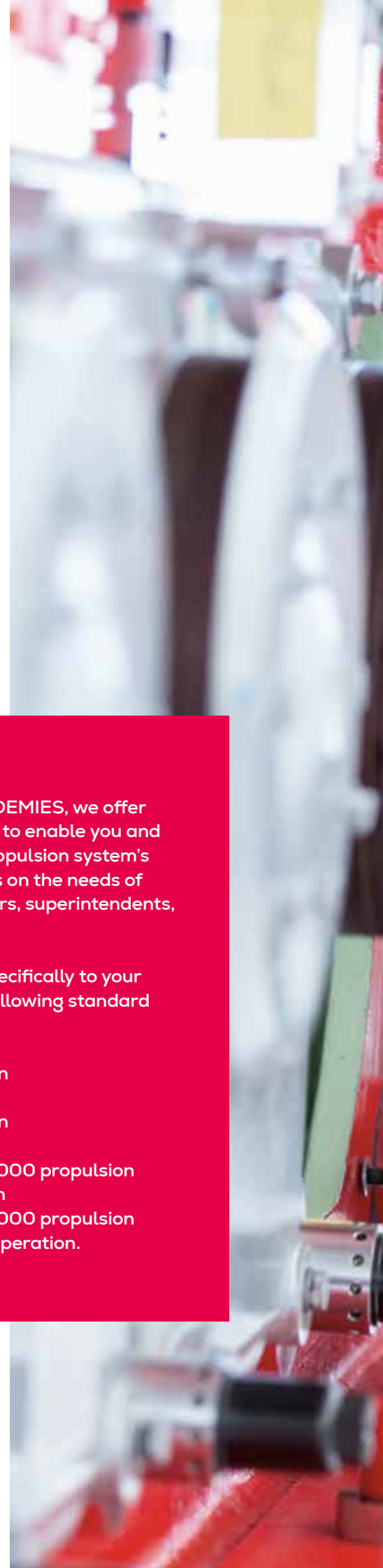



# Abbreviations and acronyms

|                     |  |
|---------------------|--|
| <b>AI</b>           | Analogue Input   |
| <b>AO</b>           | Analogue Output  |
| <b>BT</b>           | Bow Thruster CAN bus – Controller Area Network bus is a standard designed to allow microcontrollers and devices to communicate with each other in applications without a host computer |
| <b>CC</b>           | Closed Contact   |
| <b>CMS</b>          | One of two LPCU Control Modules – CMS-A and CMS-B  |
| <b>CPP</b>          | Controllable Pitch Propeller   |
| <b>DG</b>           | Diesel Generator / Generating set  |
| <b>DI</b>           | Digital Input  |
| <b>DO</b>           | Digital Output   |
| <b>DP</b>           | Dynamic Positioning / Dyn Pos  |
| <b>DP2</b>          | IMO requirements for Dynamic Positioning class 2   |
| <b>EcoOptimizer</b> | Optional fuel-saving concept for Alpha CPP solutions   |
| <b>ECP</b>          | Emergency Clutch-out Panel   |
| <b>EHP</b>          | Engine Handle Panel  |
| <b>ESP</b>          | Emergency Stop Panel   |
| <b>ECR</b>          | Engine Control Room  |
| <b>FPP</b>          | Fixed Pitch Propeller  |
| <b>GPS</b>          | Global Positioning System  |
| <b>GPRMC</b>        | Specific information sentence from the GPS   |
| <b>HPU</b>          | Hydraulic Power Unit, provides pressurised hydraulic oil for CP Propeller pitch setting  |
| <b>I/O</b>          | Input/Output   |
| <b>JS</b>           | JoyStick   |
| <b>LPCS</b>         | Local Propulsion Control System, fitted on propeller HPU   |
| <b>LPCU</b>         | Local Propulsion Control Unit  |
| <b>LOP</b>          | Local Operator Panel   |
| <b>LOP-E</b>        | Local Operator Panel – Engine  |
| <b>LOP-P</b>        | Local Operator Panel – Propeller   |
| <b>Master Clock</b> | Provides timing signals to synchronize slave clocks as part of the ship's clock network. See ZDA   |
| <b>ME</b>           | Main Engine  |
| <b>MHP</b>          | Manoeuvre Handle Panel   |
| <b>MIMIC</b>        | Provides pictorial view of a system network, e.g. with speed, power, pressure and temps  |

|                        |   |
|------------------------|---|
| <b>Modbus</b>          | Serial communications protocol originally published by Modicon for transmitting information between electronic devices and networks |
| <b>NFU</b>             | Non Follow Up panel   |
| <b>NMEA</b>            | National Marine Electronics Association (a unifying force behind the marine electronics industry)                                   |
| <b>PCP</b>             | Propulsion Control Panel  |
| <b>PCS</b>             | Propulsion Control System   |
| <b>PCU</b>             | Propulsion Control Unit, the unit containing the central PLC of the PCS   |
| <b>PIP</b>             | Propeller Indicator Panel   |
| <b>PLC</b>             | Programmable Logic Controller   |
| <b>PMS</b>             | Power Management System   |
| <b>PS</b>              | Port Side   |
| <b>PTH</b>             | Power Take-Home   |
| <b>PTI</b>             | Power Take-In   |
| <b>PTO</b>             | Power Take-Off  |
| <b>SaCoS</b>           | Engine Safety and Control System  |
| <b>SB</b>              | Starboard Side  |
| <b>SFOC</b>            | Specific fuel oil consumption   |
| <b>SG</b>              | Shaft Generator / Shaft Alternator  |
| <b>SOLAS</b>           | IMO's International Convention for the Safety of Life at Sea (SOLAS), 1974  |
| <b>SOG</b>             | Speed Over Ground   |
| <b>Speed Pilot</b>     | Alpha Speed Pilot solution for economical cruising  |
| <b>Synchro phasing</b> | Synchronization of rotational speed for multi-engine / multi propeller installations  |
| <b>TISO</b>            | Twin-In Single-Out  |
| <b>TOP</b>             | Telegraph Order Panel   |
| <b>UTC</b>             | Worldwide time system – Coordinated Universal Time  |
| <b>VDR</b>             | Voyage Data Recorder  |
| <b>ZDA</b>             | Identifies UTC time, day, month, and year, local zone number, and local zone minutes from a GPS.                                    |

# Everllence

## **Everllence**

Niels Juels Vej 15  
9900 Frederikshavn  
Denmark  
P +45 96 20 41 00  
info-frh@everllence.com  
www.everllence.com

MAN Energy Solutions SE has been renamed to Everllence SE and its products are being rebranded from "MAN" and/or "MAN Energy Solutions" to "Everllence". As this is an ongoing process, any reference to "MAN" and/or "MAN Energy Solutions" is actually a reference to "Everllence".

All data provided in this document is non-binding. This data serves informational purposes only and is not guaranteed in any way. Depending on the subsequent specific individual projects, the relevant data may be subject to changes and will be assessed and determined individually for each project. This will depend on the particular characteristics of each individual project, especially specific site and operational conditions. (5510-0141-02)

Copyright © Everllence.  
EVR 000275EN-250600, GKM-FRH